

UK

HE-VA

Operating Instructions
Spare Parts List
Declaration of Conformity



Warning: Be sure to read the operation instructions before using the machine.

King-Roller

12.3 m - 15.3 m - 16.3 m - 18.3 m - 20.3 m

Manual no.: 8000301-22 031024



N. A. Christensensvej 34
DK-7900 Nykøbing Mors

Tel: 97724288
www.he-va.com

Summary drawing / Contents

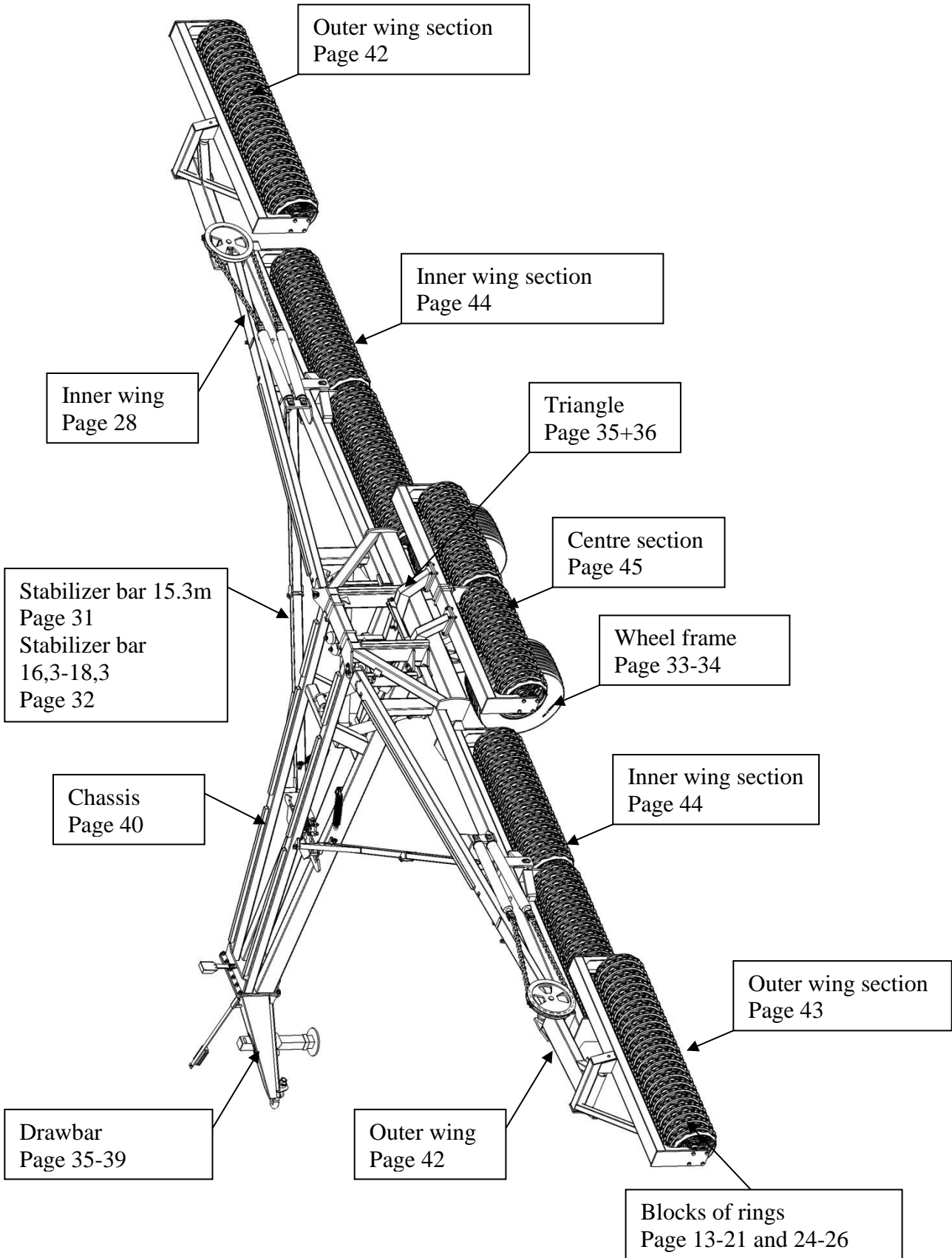

Contents

*

SUMMARY DRAWING / CONTENTS	2
EC DECLARATION OF CONFORMITY	2
MACHINE DESCRIPTION	3
FIELDS OF APPLICATION	3
DELIVERY CHECK	3
INSTRUCTIONS REGARDING UNLOADING AND FINAL MOUNTING	3
END STOP VALVE ADJUSTMENT:	4
ADJUSTMENT OF CENTER SECTION AND END STOP VALVE WITH RINGS MOUNTED	5
SAFETY INSTRUCTIONS.....	6
GENERAL INFORMATION	6
INSTRUCTIONS ON TRANSPORT ON PUBLIC ROADS.....	6
FRONT AXLE LOAD.....	6
SAFETY – AND OTHER MARKINGS ON THE MACHINE.....	7
MAINTENANCE.....	8
TECHNICAL SPECIFICATIONS.....	9
UNFOLDING	10
FOLDING	10
CONSOLIDATION	11
SAT-SYSTEM.....	12
SPAREPARTS:	13
BLOCK OF RINGS NO. 1+5 (12.3M + 15.3M)	13
BLOCK OF RINGS NO. 1+5 (16.3+18.3+20.3M)	15
BLOCK OF RINGS NO. 3	18
BLOCK OF RINGS NO. 2+4.....	21
RING TYPES:.....	24
SUPPORT BEARING:	27
RUBBERDAMPED BEARING (ADDITIONAL EQUIPMENT).....	28
INNER WING:	28
STABILIZER BAR 15.3M	31
STABILIZER BAR 16.3M - 18,3M – 20,3M	32
WHEEL FRAME 12,3 - 15,3M.....	33
WHEEL FRAME 16,3 - 18,3 – 20,3M	34
TRIANGLE UNTIL MACHINE NO: 347247	35
TRIANGEL FROM MACHIN NO. 347248.....	36
DRAWBAR 12,3 - 15,3M.....	37
DRAWBAR 12,3 - 15,3 - 16,3 - 18,3 - 20,3M,	38
DRAWBAR 12,3 - 15,3 - 16,3 - 18,3 - 20,3M,	39
CHASSIS	40
OUTER WING	42
OUTER WING SECTION	43
INNER WING SECTION	44
CENTERSECTION	45
HYDRAULICS.....	45
BRACKET FOR ACCUMULATOR	45
HYDRAULIC CIRCLE: CENTRE SECTION / CHAIN CYLINDER FOR OUTER WING SECTION.....	46
HYDRAULIC CIRCLE: SIDE SECTION / WHEEL FRAME / LOCKING CLAW	49
HYDRAULIC CIRCLE: SUPPORTING LEG	51
BRAKES.....	52
HYDRAULIC BRAKE.....	52
AIR BRAKE.....	53
LED - LIGHT SET	55
LIGHTING SET: EL. DIAGRAM	56



EC DECLARATION OF CONFORMITY

in accordance with the EU Machinery Directive 2006/42/EC
applicable as from December 29th 2009:

HE-VA ApS
N. A. Christensensvej 34,
DK-7900 Nykøbing Mors

hereby confirms that the following machine has been manufactured in accordance
with the Council Directive 2006/42/EC.

The declaration comprises the following machine:

King-Roller 12.3m – 15.3m - 16,3m - 18,3m - 20,3m

Nykøbing the 01 June 2010

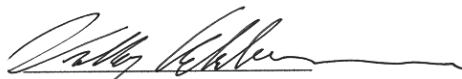

Villy Christiansen

The undersigned is furthermore authorised to compile technical documentation for the above machine.



Machine Description

Fields of application

King-Roller is a 5-section hydraulic roller with wheels. King-Roller packs the ploughed soils, while consolidating it to press stones into the ground. King-Roller is available in working widths of 12.3m - 15.3m - 16,3m - 18,3m and 20,3m with a choice of 10 different ring types. (20,3m = 4 choises)

The independent centre-suspended sections ensure a flexible roller which follows the contours of the field – the centre section has the same flexible independent abilities. Thanks to the Hydraulic Adjustable Transfer-system, which distributes the weight of the construction evenly on all 5 sections (drawbar, cylinder and wheels), the soil pressure is uniform in the entire working width. The transfer from working to transport position is hydraulic, and the low and compact construction permits a safe and stable transport width of only 3.00m.

Delivery check

Check the roller for any damage. Check the hydraulic hoses for cuts and squeezing damage. Check also that the other hydraulic components have not been damaged during transport.

Check that the frame construction has not been damaged. You should also check that the blocks of rings have not been exposed to impacts, which may have damaged the rings or the double-sealed ball bearings.

Finally check that the transport wheel nuts are tightened and OK. Check the air pressure in the tyres

Instructions regarding unloading and final mounting

To minimize freight size, the King-Roller is delivered partly disassembled. It is therefore necessary for the dealer to assemble the roller before delivery to the user.

Attach the roller to a tractor. As the roller tends to be **heavier at the back** during unfolding, causing significant upward strain on the drawbar, the tractor must be equipped with forks or a similar type of safety above the towing eye.

Unfold the roller to working position – however avoid raising the wheel frame.

Warning !

As the back part of the roller will be heavy when folding and folding out the roller, the roller must be coupled in **fork-shaped** drawbar or with a **protection above the draw bar**

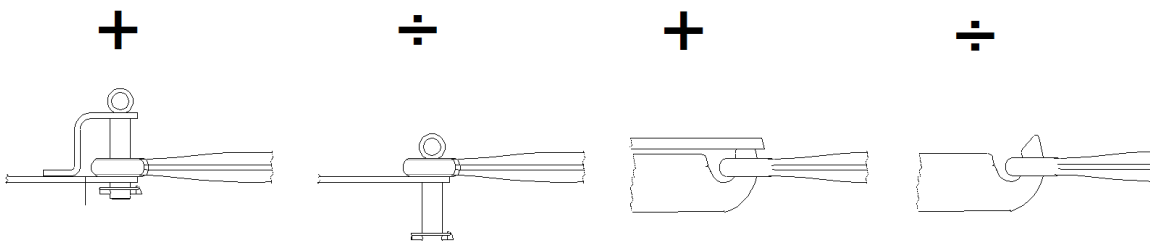

Raise the roller blocks into position under the frame and mount them in the following order:

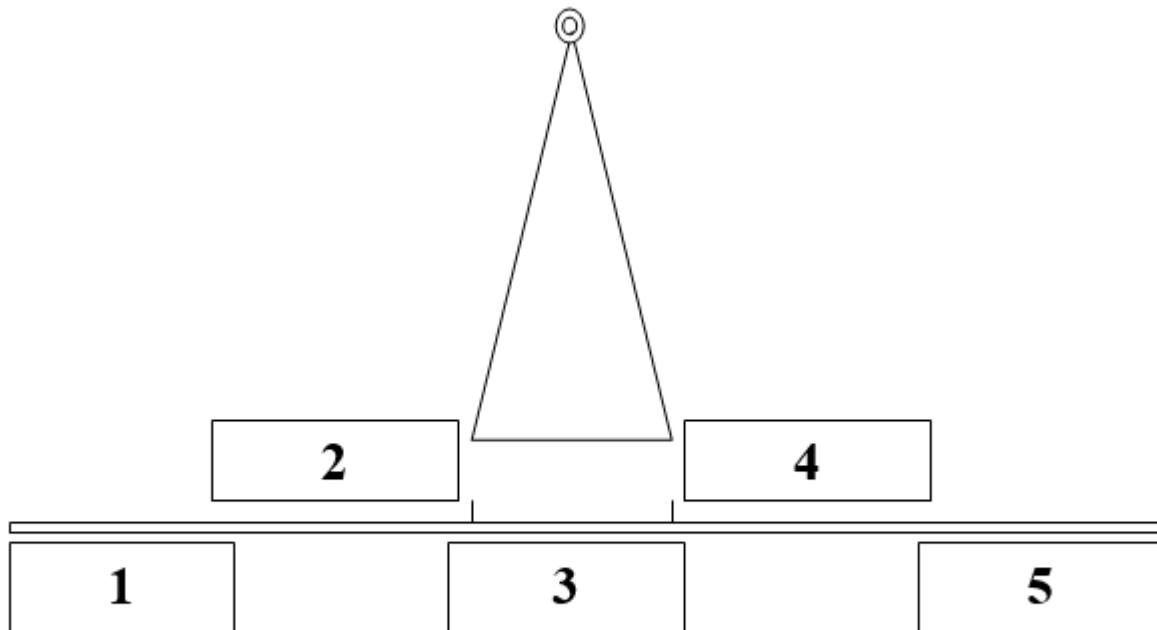

Block no. 2 and no. 4 are mounted by 

Mount block no. 3, then block no. 1 and finally block no. 5.

Remember to tighten up all bolts according to specification table before any operation of the machine.

End stop valve adjustment:

Adjust all valves as shown below

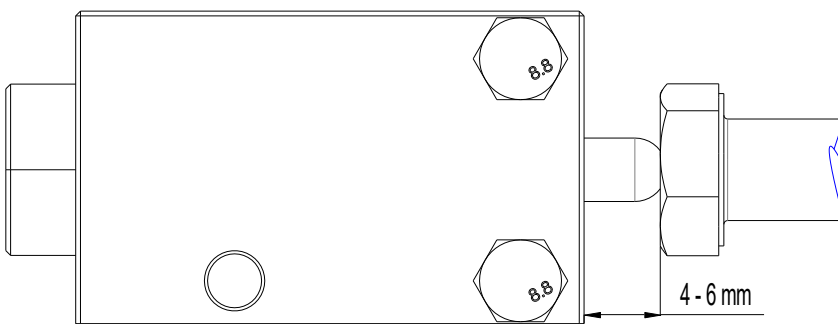

Adjustment of center section and end stop valve with rings mounted

1. Place the machine on a horizontal floor. Use a spirit level on the chassis frame to check.



2. Screw all three adjusting bolts to minimum length.
3. Lift centre section to the top position with hydraulics.
4. Adjust the two M20 bolts until the center section is horizontal. Use spirit level.
Tighten all nuts
5. Adjust the M16 bolt until the end stop valve is pressed to the bottom. Tighten all nuts.
6. Test adjustments by running the center section up/down with the hydraulics and check the end stop valve is pressed fully in. Readjust if necessary.

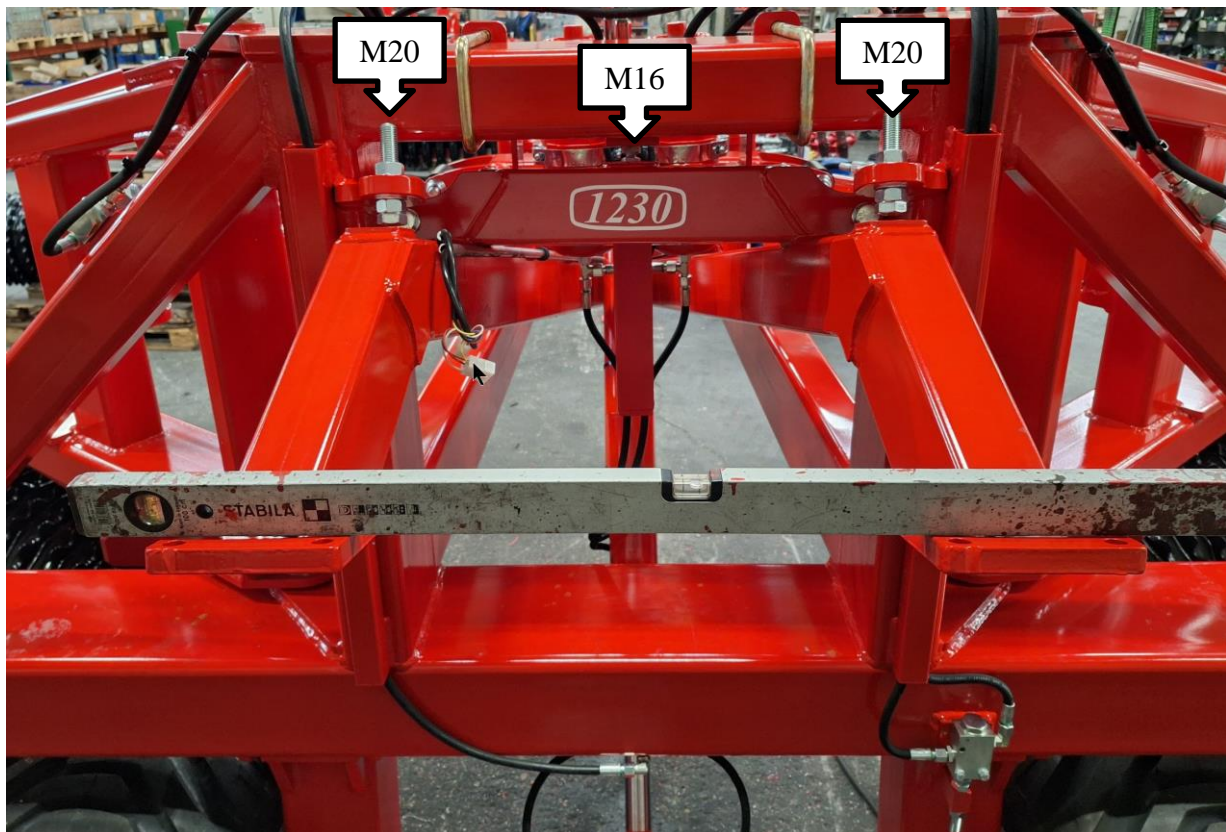

Safety instructions

General information

Do not start-up the machine if there are persons in **exposed positions**¹ within a **hazardous area**.²

When persons are in exposed positions (e.g. in connection with adjustment, maintenance, attachment and uncoupling), the following conditions must be observed:

1. The machine must be lowered to firm ground.
2. The hydraulics must be relieved.
3. The tractor must be stopped and the key removed from the ignition switch.
4. The driver must ensure that no persons are in exposed positions during the operation.



Using Pivoting Crossbar:
Because of weight distribution: ALWAYS place liftarms in top position before unfolding and folding

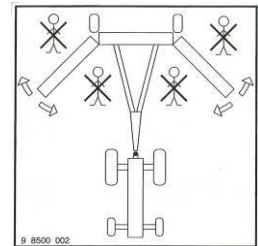

Most accidents that happen in connection with the operation, transport and maintenance of machines are caused by non-compliance with the most elementary safety conditions.

Therefore it is vital that anybody working at the machine carefully complies with the safety instructions as well as other instructions applying to the machine.

The machine may only be operated, maintained and repaired by persons, who are familiar with this work and who are further familiar with the possible elements of danger with this particular machine.

Instructions on transport on public roads

Check before transport on public roads that the attachment of the machine at the tractor is in accordance with the local rules and regulations in force (permitted total weight, permitted axle load, transport width, lights, warning signs, etc.).

The transport wheels and construction of the King-Rollers were designed for maximum speeds of 25 km/h.

If this speed is exceeded, all warranty claims are repealed.

Front axle load

After the attachment of the machine and at maximum load, the driving properties of the tractor must be checked. Check that the front axle is sufficiently loaded. As a minimum, the front axle load must be 20% of the tractor weight. Permitted axle load and permitted total weight for the tractor must always be observed.

NB! The driving, controlling and braking properties are affected by the attached machine combination.

¹ Persons in exposed positions: Any person who is wholly or partly within a hazardous area.

² Hazardous area: On and under the machine within a distance of 10 m from the machine.



Safety – and other markings on the machine

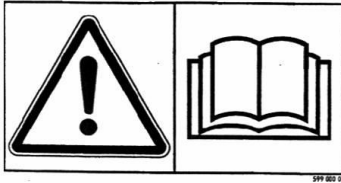

Study the Operating Instructions thoroughly before any operation of the machine and observe all safety instructions.

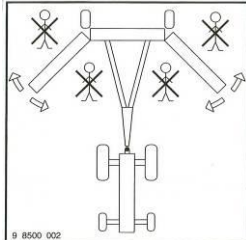

Take care that no persons are within the machine's hazardous area during the unfolding and folding procedure..



Plate with number and year of manufacture

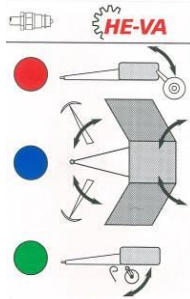

Indication label for the machine's hydraulic systems:

Red: Transporthjul op/ ned

Blue: Hydraulics for folding the outer wing sections and weight transfer system

Green: Support leg

**HUSK - PLEASE NOTE -
ACHTUNG - ATTENTION**
EFTERSPÆND BOLTE
TIGHTEN UP THE BOLTS
BOLZEN NACHZIEHEN
RESSERRER LES BOULONS

Tighten up the bolts regularly. If this is not performed, our warranty obligations will no longer apply.

Maximum torque according to ISO 898-1 in Nm. With lubricated thread			
Metric thread	Quality 8.8	Quality 10.9	Quality 12.9
M10x1,5	38	54	63
M12x1,75	66	95	110
M14x2,0	105	150	176
M16x2,0	164	235	274
M18x2,5	233	323	377
M20x2,5	331	458	535
M22x2,5	450	622	727
M24x3,0	572	791	925
Wheel nut M18x1,5 fine thread		360 Nm	
Wheel nut M22x1,5 fine thread		550 Nm	



Maintenance

- A. After every approx. 10 hours of operation retighten wheels, bearings and locking rings. Hoses, fittings and cylinders checked for leaks and tighten.
- B. For each approximately 10 hours of operation lubricate all moving parts in the wings - and the side sections, as well as the lubrication points on the cylinders. For about every 30 hours of operation lubricate the cylinder studs.

Important:

The hydraulic system is filled with oil type Hydro Texaco HD32
Specification DIN 51524-3 / ISO 11158 L-HV

After the season the roller should be cleaned. This is easily done with a high-pressure cleaner. Make sure that all earth and dirt particles are removed. Do not use high-pressure water directly on ball bearings, cylinders, lubricating nipples and link connections as this may cause water to penetrate these items. After the washing all lubricating points must be lubricated and the wheel frame cylinder greased. When the roller is dry it can be sprayed with oil.

Important:

Coat the piston rods in grease.

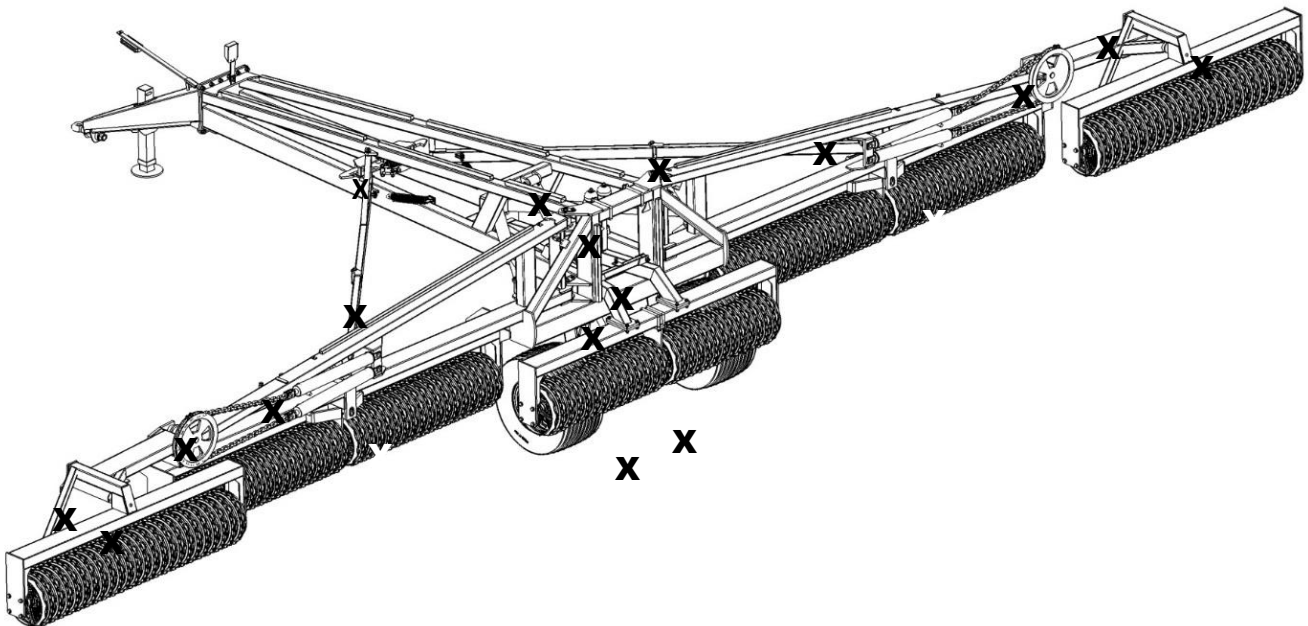

X = Lubricating places

IMPORTANT! The ball bearings should only be lubricated with 1-2 strokes as the sealing rings could otherwise be pressed out. Every 20 hours



Technical specifications

	12,3m	15,3m	16,3m	18,3m	20,3m
Working width	12,3m	15,3m	16,3m	18,3m	20,3m
Transport width	3,00m	3,00m	3,00m	3,00m	3,00m
Machine length	6,55m	7,75m	8,35m	8,35m	9,55m
Wheels	550/45x22.5 – 16 Ply		560/45 R22.5 LI 163A8		
Air pressure	2.8		4.00		
Number of hydr. outlets	3 double-acting		3 double-acting		
Hydraulic pressure (minimum):	190 bar		190 bar		
Oil type:	Hydro Texaco HD32		Hydro Texaco HD32		
Voltage	12 volt		12 volt		
Working speed recommended	7 - 10 km		7 - 10 km		
Ringe	12,3m	15,3m	16,3m	18,3m	20,3m
Cambridge 510mm					
No. of rings	236 pcs.	292 pcs.	306 pcs.	346 pcs.	386 pcs.
Weight kg	8560 kg	9880 kg	10270 kg	11680 kg	13600 kg
Power requirement HP	170 - 200 HP	180 - 230HP	190 - 240HP	210 - 260 HP	220 - 280 HP
Cambridge 560mm					
No. of rings	236 pcs.	292 pcs.	306 pcs.	346 pcs.	386 stk
Weight kg	9310 kg	10820 kg	11280 kg	12820 kg	14280 kg
Power requirement HP	170 - 200 HP	180 - 230HP	190 - 240HP	210 - 260 HP	220 - 280 HP
Cambridge 620mm					
No. of rings	236 pcs.	292 pcs.	306 pcs.	346 pcs.	
Weight kg	10020 kg	11770 kg	12290 kg	14240 kg	
Power requirement HP	190 - 220 HP	200 - 250 HP	210 - 260 HP	230 - 280 HP	
Crosskill 485 530mm					
No. of rings	125 pcs.	153 pcs.	163 pcs.	183 pcs.	203 pcs.
Weight kg	8000 kg	9250 kg	9570 kg	11020 kg	13500kg
Power requirement HP	170 - 200 HP	180 - 230 HP	190 - 240 HP	210 - 260 HP	220 - 280 HP
Crosskill 550 600mm No. of rings					
No. of rings	125 pcs.	153 pcs.	163 pcs.	183 pcs.	
Weight kg	9400 kg	11140 kg	11610 kg	13080 kg	
Power requirement HP	170 - 200 HP	180 - 230 HP	190 - 240 HP	210 - 260 HP	
2D Bølgering 500mm					
No. of rings	150 pcs.	187 pcs.	199 pcs.	223 pcs.	248 pcs.
Weight kg	7480 kg	9070 kg	9330kg	10340 kg	12770 kg
Power requirement HP	170 - 200 HP	180 - 230 HP	190 - 240 HP	210 - 260 HP	220 - 280 HP
2D Corrugated 550mm					
No. of rings	150 pcs.	187 pcs.	199 pcs.	223 pcs.	248 stk
Weight kg	8020 kg	9570 kg	9840 kg	11140 kg	12950 kg
Power requirement HP	170 - 200 HP	180 - 230 HP	190 - 240 HP	220 - 270 HP	220 - 280 HP
2D Corrugated 600mm					
No. of rings	150 pcs.	187 pcs.	199 pcs.	223 pcs.	
Weight kg	8560 kg	10000 kg	10350kg	11940 kg	
Power requirement HP	180 - 210 HP	190 - 240 HP	200 - 250 HP	220 - 270 HP	
Starring 450/500					
No. of rings	244 pcs.	302 pcs.	316 pcs.	356 pcs.	396 pcs.
Weight kg	8200 kg	9830 kg	10350 kg	11300 kg	12620 kg
Power requirement HP	170 - 200 HP	200 - 250 HP	190 - 240 HP	210 - 260 HP	220 - 280 HP
Starring 550/600					
No. of rings	244 pcs.	302 pcs.	316 pcs.	356 pcs.	
Weight kg	9470 kg	11400 kg	12000 kg	13160 kg	
Power requirement HP	190 - 220 HP	200 - 250 HP	210 - 260 HP	230 - 280 HP	



Unfolding



Using Pivoting Crossbar:

Because of weight distribution: **ALWAYS** place liftarms in top position before unfolding and folding

1. Check that the male quick couplings mounted from the factory fit the tractor's female quick couplings.
2. When (un)folding, the King-Roller should be **stationary** on level, firm ground, while the tractor is able to move freely.
3. Activate the hydraulics marked with **red** to unlock the side section transport safety, then pivot the side sections fully backwards. The oil flow automatically switches to the wheel frame. Pull the wheel frame forward then up.
4. With the wheels completely raised, activate the hydraulics marked with **blue** to fold the outer wing sections into working position.

The Hydraulic Adjustable Transfer-system (S.A.T. System) of the King-Roller is connected to the folding system. The S.A.T. System transfers weight from sections 2 & 4, which carry the main frame, onto sections 1, 3 & 5. This allows you to adjust the hydraulic weight transfer system to ensure a uniform pressure in the entire working width.

The oil pressure in the S.A.T. System can be monitored on the manometer. The hydraulics marked with blue allows you to set the desired working pressure: **80 bar** is recommended.

IMPORTANT: Take care that no persons are within the machine's hazardous area during the unfolding and folding procedure

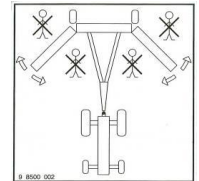

Folding

1. When (un)folding, the King-Roller should be **stationary** on level, firm ground, while the tractor is able to move freely.
2. Activate the hydraulics marked with **blue** to fold the outer wing sections from working position into transport position.
3. Activate the hydraulics marked with **red** to lower the wheel frame down and backwards. When the wheel are fully folded, the oil flow automatically switches to side section folding. When the side sections are fully folded, the transport safety activates automatically.



Consolidation

The transport wheels are to be lowered only when folding into transport position.

Never drive the roller on the wheels in working position, as it would put inappropriate strain on the construction of the machine.

Maximum working speed 10 km/h.

When turning on the headland, turn in the widest possible curves. Only turn as sharply as to keep the rings rotating in a forward direction.

Do not drive over large or earth-fast stones, as it may damage the rings.

When working on varying soil types, it is necessary to check the work results regularly, and possibly adjust the Hydraulic Transfer System. Current settings can be read on the manometer in the front of the roller.

The recommended working pressure is 80 bar. The best way to check the work results is for the driver to inspect the field crosswise of the working direction. If the consolidation seems uneven, it is necessary to adjust the hydraulic pressure:

If the consolidation is heaviest on the middle and wing outer sections, the pressure should be decreased to reduce the weight transfer. This will put more weight on the inner wing sections (2 & 4).

If the consolidation is heaviest on the inner wing sections (2 & 4), the pressure should be increased. This will put more weight on the centre section and outer wing sections.

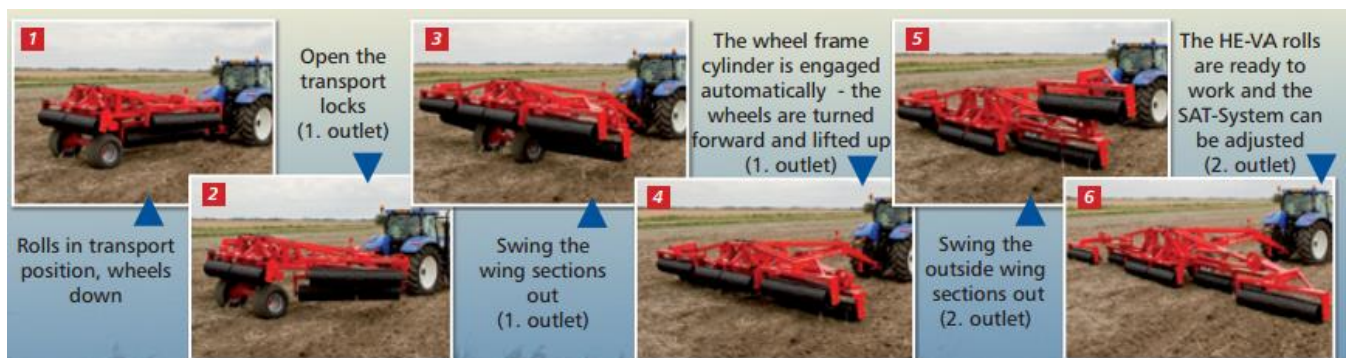

SAT-System

King-Roller's hydraulic folding system is linked to two accumulators and a pressure gauge.



The pressure gauge allows the operator to set the weight transfer level to ensure even consolidation across the full width. The KingRoller's main frame is supported by the two wing sections (O) of photo. By this SAT-System the necessary part of the roll's weight is transferred to the centre and the outside wing sections. (□) of photo.



All five roller sections on HE-VA King-Roller are centre suspended and with independent flotation resulting in a perfect contour following of the King-Roller

The design of HE-VA King-Roller can withstand higher working loads and HE-VA King-Rollers are also heavier than most of the other similar rolls, ensuring a perfect consolidation.



Spareparts:

Block of rings no. 1+5 (12.3m + 15.3m)

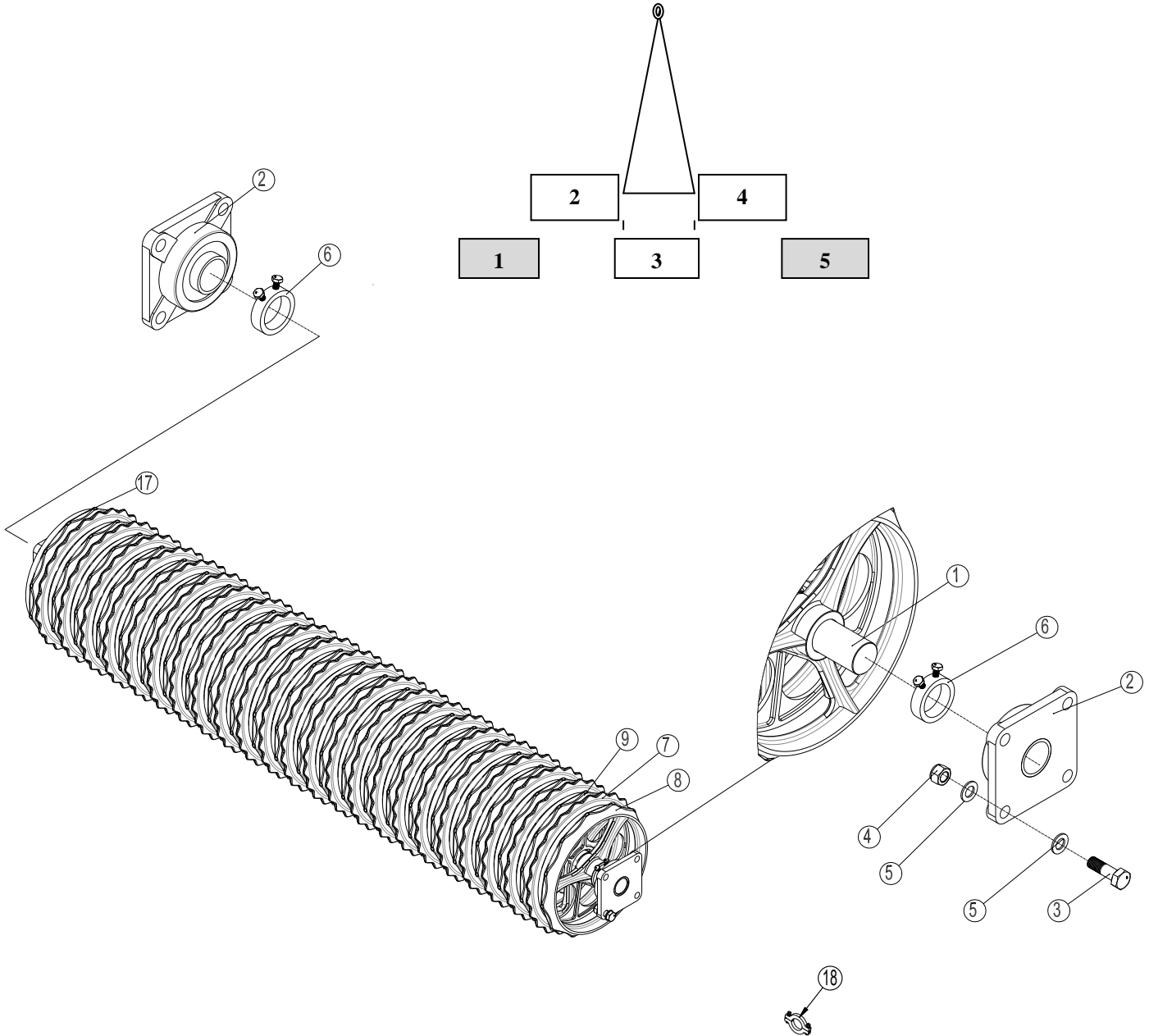

Pos.	Item no.	Designation	12,3m	15,3m
1	678672720	Axle 2720mm Ø60 CrNiM06		2
1	678672520	Axle 2520 mm Ø60 (Discontinued 12,5m)		
1	678672420	Axle 2420mm Ø60 CrNiM06	2	
2	690140808	Bearing complete UCF 312 (Ø60)	4	4
3	690103173	Bolt M20x70 10.9	16	16
4	690113009	Self-locking nut M20	16	16
5	690117005	Facet plate Ø20	32	32
6	671040400	Stop ring w/bolt Ø60 axle	4	4
		Ring types: Shown on page 24-26		
7	690150032	Cambridge serrated ring 510 mm 21”	42	44
7	690150102	Cambridge serrated 560 mm 22,5”	42	44
7	690150046	Cambridge serrated ring 620 mm 24”	42	44
8	690150042	Cambridge plain ring 510 mm (reduced hub 80mm) 21”	2	2
8	690150109	Cambridge plain ring 560 mm (reduced hub 80mm) 22,5”	2	2
8	690150050	Cambridge plain ring 620 mm (reduced hub 80mm) 24”	2	2
9	690150030	Cambridge plain ring 510mm 21”	42	44
9	690150049	Cambridge plain ring 620mm 24”	42	44
10	690150007	Cam ring 22” Ended 1st.oct 2011		
10A	690150063	Star ring Ø500, center Ø135, GGG50	42	44
10B	690150064	Star ring Ø450, m/hals Ø60 GGG50	42	44
10C	690150065	Star ring Ø600, center Ø135, GGG50	42	44
10D	690150066	Star ring Ø550, m/hals Ø60 GGG50	42	44
11	690150013	Corrugated ring Ø500 Ended april 2011		
11A	690150042	2D- Corrugated ring Ø510 New from 1. april 2011	27	30
11B	690150050	2D- Corrugated ring Ø620 New from 1. april 2011	27	30
11C	690150104	2D - Corrugated ring Ø550	27	30
12	690150028	Plain ring Ø505	28	30
13	690150034	Crosskill ring Ø485 (Ø60)	48	52
13	690150074	Crosskill ring Ø550 (Ø60)	48	52
14	690150011	Loose Crosskill ring Ø530	43	48
14	690150075	Loose Crosskill ring Ø600	43	48
15	690150035	Hub for loose Crosskill ring	43	48
15	690150076	Hub for loose Crosskill ring Ø104/Ø60	43	48
17	630764030	Cambridge plain ring 21” hub width 82 mm	2	2
17	630764040	Cambridge plain ring 24” hub width 82 mm	2	2
18	690150090	Spacer rings 15 mm, incl bolts		
18	690150099	Spacer rings 20 mm, incl bolts		
18	690150091	Spacer rings 25 mm, incl bolts		



Block of rings no. 1+5 (16.3+18.3+20.3m)

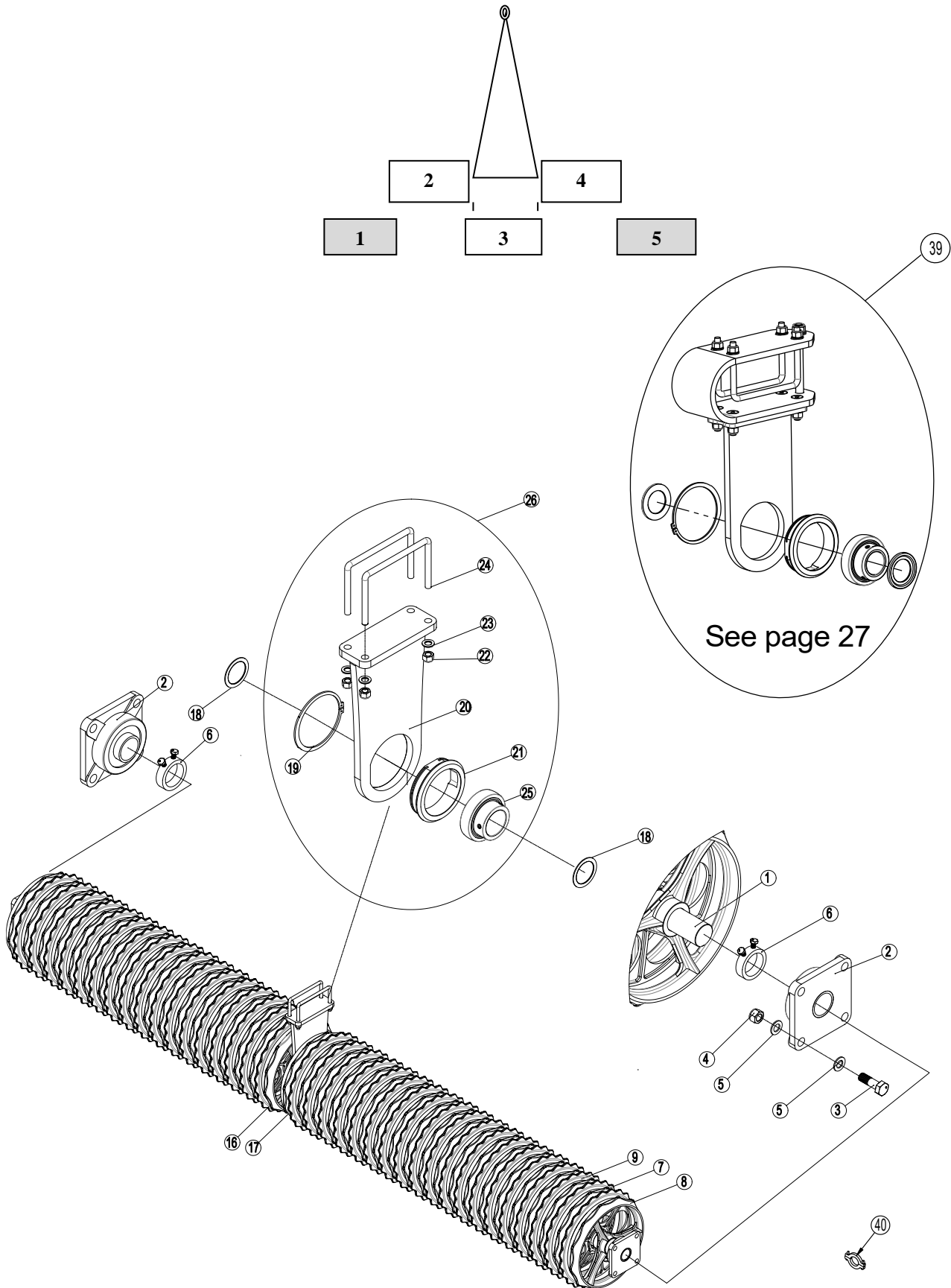

Pos.	Item number	Designation	16,3	18,3	20,3
1	678613150	Axle 3150 mm Ø60 St.60	2		
1	678614150	Axle 4150 mm Ø60 St.60		2	
1	678614650	Aksel 4650 mm Ø60 St.60			2
2	690140808	Bearing complete UCF 312 (Ø60)	4	4	4
3	690103173	Bolt M20x70 10.9	16	16	16
4	690113009	Self-locking nut M20	16	16	16
5	690117005	Facet plate Ø20	32	32	32
6	671040400	Stop ring w/bolt Ø60 axle	4	4	4
		Ringtypes: Shown on page 24-26			
7	690150032	Cambridge serrated ring 510 mm 21"	54	72	80
7	690150102	Cambridge serrated ring 560 mm 22,5"	54	72	80
7	690150046	Cambridge serrated ring 620 mm 24"	54	72	
8	690150042	Cambridge plain ring 510 mm (reduced hub 80mm)	2	2	2
8	690150109	Cambridge plain ring 560 mm (reduc, hub 80mm)	2	2	2
8	690150050	Cambridge plain ring 620 mm (reduced hub 80mm)	2	2	
9	690150030	Cambridge plain ring 510mm 21"	54	72	80
9	690150101	Cambridge plain ring 560mm 22,5"	54	72	80
9	690150049	Cambridge plain ring 620mm 24"	54	72	
10	690150007	Cam ring 22" Ended 1st.oct 2011			
10A	690150063	Star ring Ø500, Center Ø135 GGG50	58	76	86
10B	690150064	Stjernering Ø450 m/hals Ø60 GGG50	58	76	86
10C	690150065	Stjernering Ø600, Center Ø135, GGG50	58	76	
10D	690150066	Stjernering Ø550 m/hals Ø60 GGG50	58	76	
11	690150013	Corrugated ring Ø500 Ended from april 2011			
11A	690150042	2D- Corrugated ring Ø500 New from april 2011	74	98	108
11B	690150050	2D- Corrugated ring Ø600 New from april 2011	74	98	
11C	690150104	2D- Corrugated ring Ø550	74	98	
12	690150028	Plain ring Ø505 Ended			
13	690150034	Crosskill ring Ø485 (Ø60)	61	81	91
13	690150074	Crosskill ring Ø550 (Ø60)	61	81	
14	690150011	Loose Crosskill ring Ø530	51	68	75
14	690150075	Loose Crosskill ring Ø600	51	68	
15	690150035	Hub for loose Crosskill ring	51	68	75
15	690150076	Hub for loose Crosskill ring Ø104/Ø60	51	68	
16	630764031	Cambridge plain ring 21" hub width 72 mm	2	2	2
16	630764039	Cambridge gplain ring 22,5" hub width 72 mm	2	2	2
16	630764041	Cambridge plain ring 24" hub width 72 mm	2	2	
16	630764048	Cambridge smooth ring Ø620/Ø60, cast steel w/red. hub (72mm) from machine no. 341981	2	2	



Pos.	Item number	Designation	16,3	18,3	20,3
17	630764030	Cambridge plain ring 21" hub width 82 mm	2	2	2
17	630764040	Cambridge plain ring 24" hub width 82 mm	2	2	
17	630764047	Cambridge smooth ring Ø620/Ø60, cast steel w/red. hub (72mm) from machine no. 341981	2	2	
18	7355000	Thrust plate, narrow f/ UCF312 hub	4	4	4
18a	690600015	Distance bush Ø60 L=15	2	2	2
19	691370150	Seeger circlip-ring outer Ø150 DIN471	2	2	2
20	630670250	Support bearing	2	2	2
21	630764008	Bearing housing f/UC 312 bearing	2	2	2
22	690113008	Self-locking nut M16	8	8	8
23	690117013	Facet plate Ø16	8	8	8
24	0382852	U-bolt M16x100x200x100	4	4	4
25	690140116	Bearing UC 312 R6 (Ø60)	2	2	2
26	63067-65	Complete bearing			
39	63067-57	Support bearing w/ tension : from machine no. 345884	See page 27		
40	690150090	Spacer rings 15 mm, incl bolts			
40	690150099	Spacer rings 20 mm, incl bolts			
40	690150091	Spacer rings 25 mm, incl bolts			

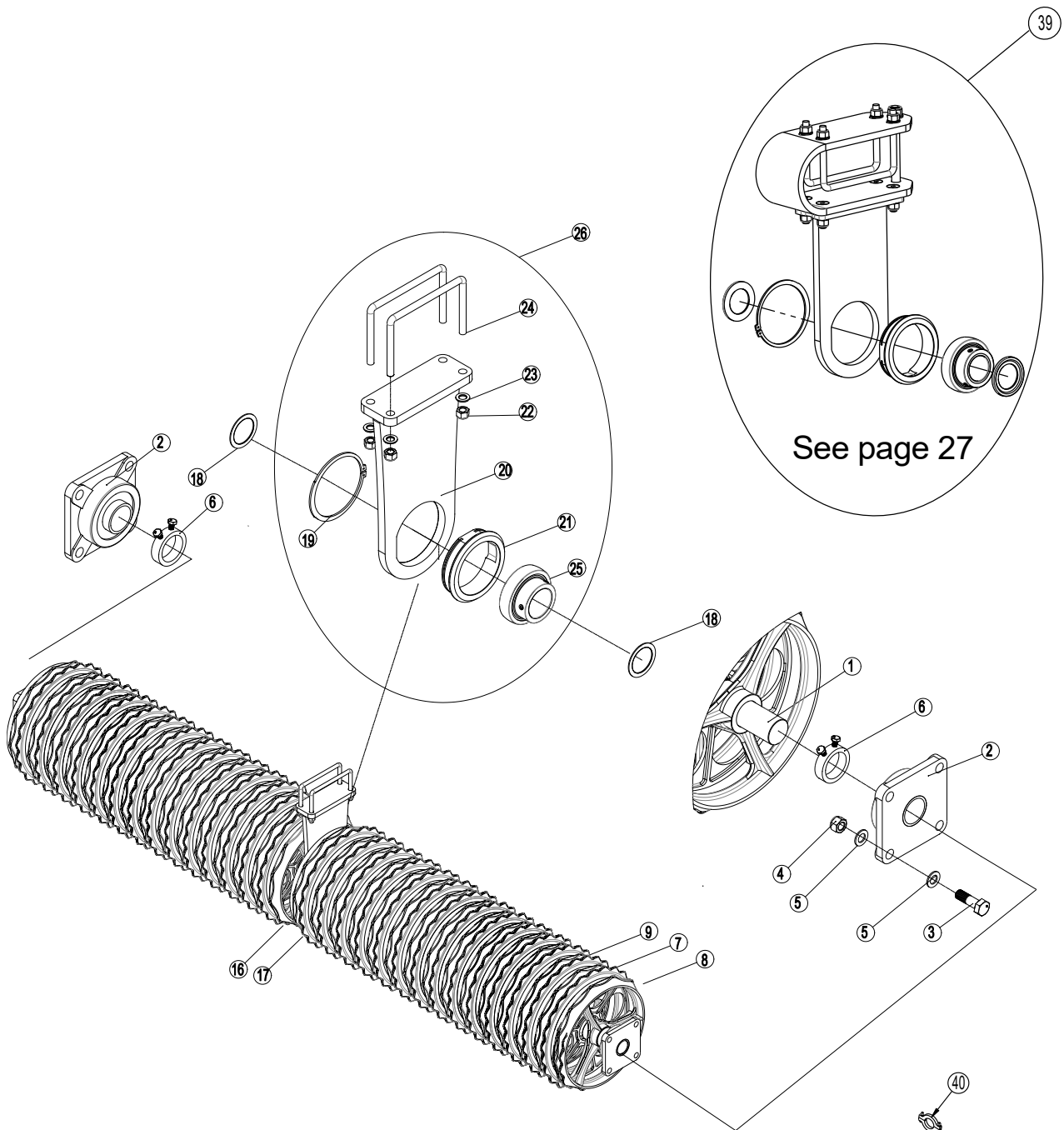
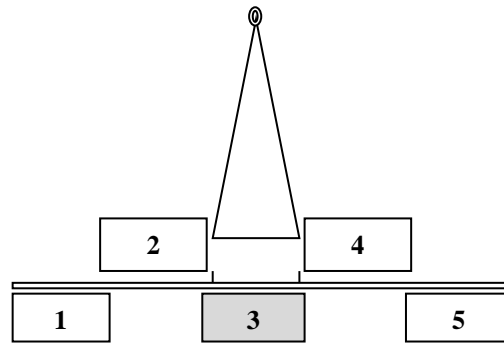

Block of rings no. 3

Pos.	Item no.	Designation	12.3	15.3	16,3	18,3	20,3
1	678612960	Axle 2960 mm Ø60 St.60	1	1	1	1	1
2	690140808	Bearing complete UCF 312 (Ø60)	2	2	2	2	2
3	690103173	Bolt M20x70 10.9	8	8	8	8	8
4	690113009	Self-locking nut M20	8	8	8	8	8
5	690117005	Facet plate Ø20	16	16	16	16	16
6	671040400	Stop ring w/bolt Ø60 axle	2	2	2	2	2
		Ringtypes: Shown on page 24-26					
7	690150032	Cambridge serrated ring 510 mm 21”	26	26	26	26	26
7	690150102	Cambridge serrated ring 560 mm 22,5”	26	26	26	26	26
7	690150046	Cambridge serrated ring 620 mm 24”	26	26	26	26	
8	690150042	Cambridge plain ring 510 mm (reduced hub 80mm)	1	1	1	1	1
8	690150109	Cambridge plain ring 560 mm (reduceret, hub 80mm)	1	1	1	1	1
8	690150050	Cambridge plain ring 620 mm (reduced hub 80mm)	1	1	1	1	
9	690150030	Cambridge plain ring 510mm 21”	23	23	23	23	23
9	690150101	Cambridge plain ring 560mm 21”	23	23	23	23	23
9	690150049	Cambridge plain ring 620mm 24”	23	23	23	23	
10	690150007	Cam ring 22” Ended oct 2011					
10A	690150063	Star ring Ø500, Center Ø135 GGG50	26	26	26	26	26
10B	690150064	Star ring Ø450 m/hals Ø60 GGG50	26	26	26	26	26
10C	690150065	Star ring Ø600, Center Ø135, GGG50	26	26	26	26	
10D	690150066	Star ring Ø550 m/hals Ø60 GGG50	26	26	26	26	
11	690150013	Corrugated ring Ø500 Ended from april 2011					
11A	690150042	2D- Corrugated ring Ø500 New from april 2011	35	35	35	35	35
11B	690150050	2D- Corrugated ring Ø600 New from april 2011	35	35	35	35	
11C	690150104	2D- Corrugated ring Ø550	35	35	35	35	
12	690150028	Plain ring Ø505 Ended					
13	690150034	Crosskill ring Ø485 (Ø60)	29	29	29	29	29
13	690150074	Crosskill ring Ø550 (Ø60)	29	29	29	29	
14	690150011	Loose Crosskill ring Ø530	24	24	24	24	24
14	690150075	Loose Crosskill ring Ø600	24	24	24	24	
15	690150035	Hub for loose Crosskill ring	24	24	24	24	24
15	690150076	Hub for loose Crosskill ring Ø104/Ø60	24	24	24	24	24
16	630764031	Cambridge plain ring 21” hub width 72 mm	1	1	1	1	1
16	630764039	Cambridge plain ring 22,5” hub width 72 mm	1	1	1	1	1
16	630764041	Cambridge plain ring 24” hub width 72 mm	1	1	1	1	
16	630764048	Cambridge smooth ring Ø620/Ø60, cast steel w/red. hub (72mm) from machine no. 341981	1	1	1	1	



Pos.	Item no.	Designation	12.3	15.3	16,3	18,3	20,3	
17	630764030	Cambridge plain ring 21" hub width 82 mm	1	1	1	1	1	
17	630764040	Cambridge plain ring 24" hub width 82 mm	1	1	1	1		
17	630764047	Cambridge smooth ring Ø620/Ø60, cast steel w/red. hub (72mm) from machine no. 341981	1	1	1	1		
18	7355000	Thrust plate, narrow f/ UCF312 hub	2	2	2	2	2	
18a	690600015	Distance bush Ø60 L=15	1	1	1	1	1	
19	691370150	Seeger circlip-ring outer Ø150 DIN471	1	1	1	1	1	
20	630670250	Support bearing	1	1	1	1	1	
21	630764008	Bearing housing f/UC 312 bearing	1	1	1	1	1	
22	690113008	Self-locking nut M16	4	4	4	4	4	
23	690117013	Facet plate Ø16	4	4	4	4	4	
24	0382852	U-bolt M16x100x200x100	2	2	2	2	2	
25	690140116	Bearing UC 312 R6 (Ø60)	1	1	1	1	1	
26	63067-65	Complete bearing						
39	63067-57	Spring support bearing from machine no. 345884	See page 27					
40	690150090	Spacer rings 15 mm, incl bolts						
40	690150099	Spacer rings 20 mm, incl bolts						
40	690150091	Spacer rings 25 mm, incl bolts						



Block of rings no. 2+4

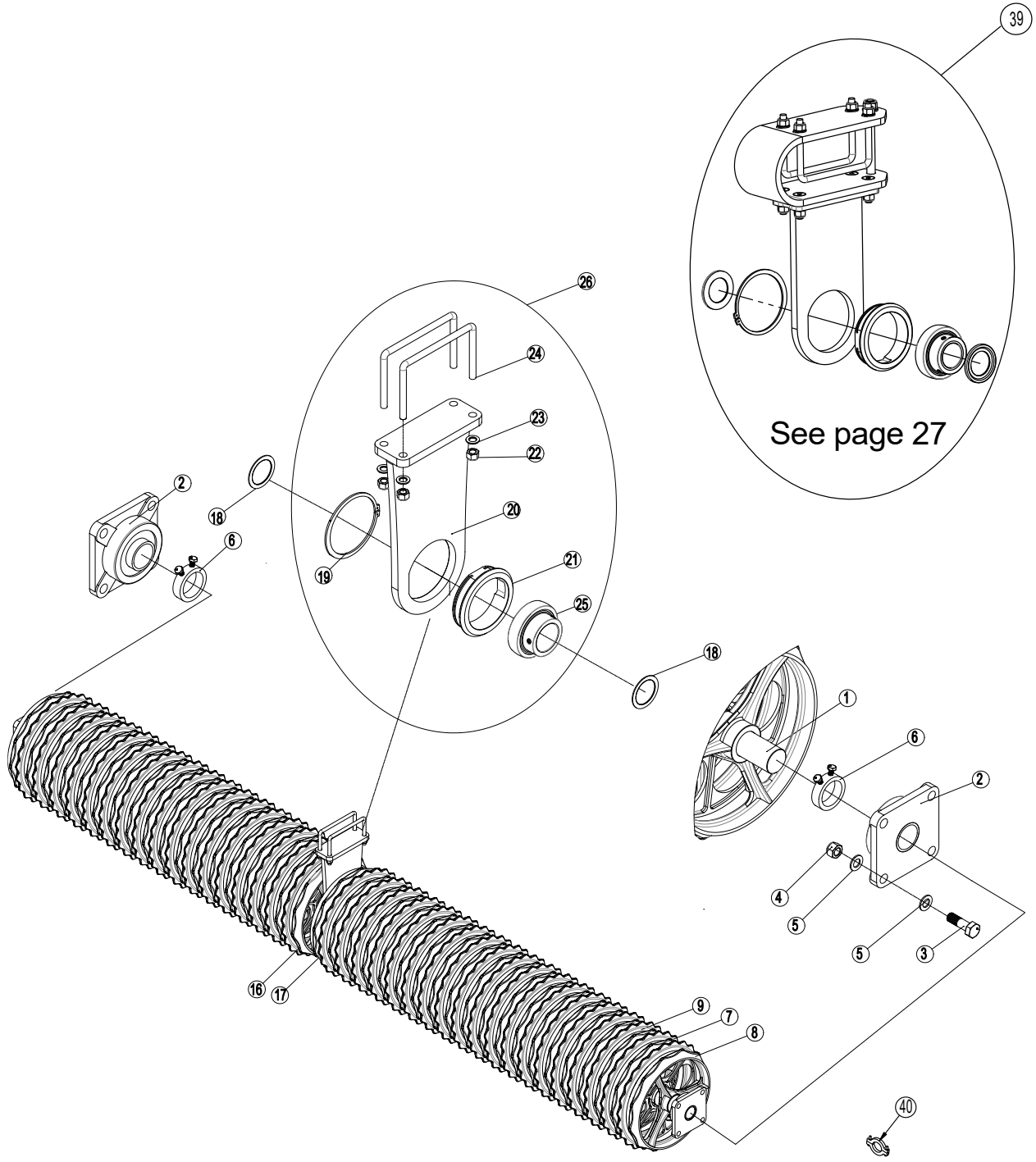
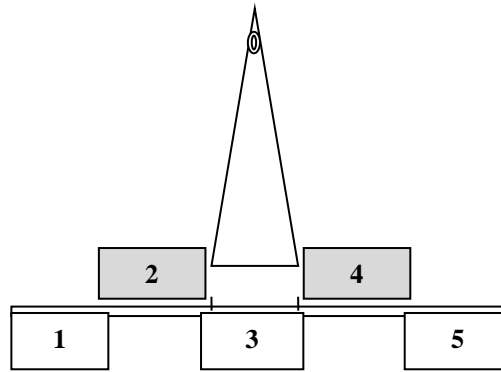

Pos.	Item no.	Designation	12.3	15.3	16,3	18,3	20,3
1	678612920	Axle 2920 mm Ø60 St.60	2				
1	678614150	Axle 4150 mm Ø60 St.60		2	2	2	
1	678614650	Axle 4650 mm Ø60 St.60					2
2	690140808	Bearing complete UCF 312 (Ø60)	4	4	4	4	
3	690103173	Bolt M20x70 10.9	8	8	8	8	8
3a	690103215	Indv. 6-kant M20x70 8.8 UH fzb	8	8	8	8	8
4	690113009	Self-locking nut M20	16	16	16	16	16
5	690117005	Facet plate Ø20	32	32	32	32	32
6	671040400	Stop ring w/bolt Ø60 axle	4	4	4	4	4
		Ringtypes: Shown on page 24-26					
7	690150032	Cambridge serrated ring 510 mm 21”	45	65	65	65	72
7	690150102	Cambridge serrated ring 560 mm 22,5”	45	65	65	65	72
7	690150046	Cambridge serrated ring 620 mm 24”	45	65	65	65	
8	690150042	Cambridge plain ring 510 mm (reduced hub 80mm)	2	2	2	2	2
8	690150109	Cambridge plain ring 560 mm (reduc, nav 80mm)	2	2	2	2	2
8	690150050	Cambridge plain ring 620 mm (reduced hub 80mm)	2	2	2	2	
9	690150030	Cambridge plain ring 510mm 21”	45	65	65	65	72
9	690150101	Cambridge plain ring 560mm 22,5”	45	65	65	65	72
9	690150049	Cambridge plain ring 620mm 24”	45	65	65	65	
10	690150007	Cam ring 22” Ended oct 2011					
10A	690150063	Star ring Ø500, Center Ø135 GGG50	50	72	72	72	80
10B	690150064	Star ring Ø450 m/hals Ø60 GGG50	50	72	72	72	80
10C	690150065	Star ring Ø600, Center Ø135, GGG50	50	72	72	72	80
10D	690150066	Star ring Ø550 m/hals Ø60 GGG50	50	72	72	72	80
11	690150013	Corrugated ring Ø500 Ended from april 2011	116	154	154	154	
11A	690150042	2D- Corrugated ring Ø500 From april 2011	69	92	92	92	109
11B	690150050	2D- Corrugated ring Ø600 From april 2011	69	92	92	92	
11C	690150104	2D- Corrugated ring Ø550	69	92	92	92	
12	690150028	Plain ring Ø505 Ended					
13	690150034	Crosskill ring Ø485 (Ø60)	56	78	78	78	91
13	690150074	Crosskill ring Ø550 (Ø60)	56	78	78	78	
14	690150011	Loose Crosskill ring Ø530	46	68	68	68	91
14	690150075	Loose Crosskill ring Ø600	46	68	68	68	
15	690150035	Hub for loose Crosskill ring	46	68	68	68	91
15	690150076	Hub for loose Crosskill ring Ø104/Ø60	46	68	68	68	91
16	630764031	Cambridge plain ring 21” hub width 72 mm	2	2	2	2	2
16	630764039	Cambridge plain ring 22,5” hub width 72 mm	2	2	2	2	2
16	630764041	Cambridge plain ring 24” hub width 72 mm	2	2	2	2	
16	630764048	Cambridge smooth ring Ø620/Ø60, cast steel w/red. hub (72mm) from machine no. 341981	2	2	2	2	



Pos.	Item no.	Designation	12.3	15.3	16,3	18,3	20,3	
17	630764030	Cambridge plain ring 21" hub width 82mm	2	2	2	2	2	
17	630764040	Cambridge plain ring 24" hub width 82mm	2	2	2	2		
17	630764047	Cambridge smooth ring Ø620/Ø60, cast steel w/red. hub (72mm) from machine no. 341981	2	2	2	2		
18	7355000	Thrust plate, narrow f/ UCF312 hub	4	4	4	4	4	
18a	690600015	Distance bush Ø60 L=15	2	2	2	2	2	
19	691370150	Seeger-circlip ring outer Ø150 DIN471	2	2	2	2	2	
20	630670250	Support bearing	2	2	2	2	2	
21	630764008	Bearing housing f/UC 312 bearing	2	2	2	2	2	
22	690113008	Self-locking nut M16	8	8	8	8	8	
23	690117013	Facet plate Ø16	8	8	8	8	8	
24	0382852	U-bolt M16x100x200x100	4	4	4	4	4	
25	690140116	Bearing UC 312 R6 (Ø60)	1	1	2	2	2	
26	63067-65	Complete bearing						
39	63067-57	Spring support bearing from machine no. 345884	See page 27					
40	690150090	Spacer rings 15 mm, incl bolte						
40	690150099	Spacer rings 20 mm, incl bolte						
40	690150091	Spacer rings 25 mm, incl bolte						

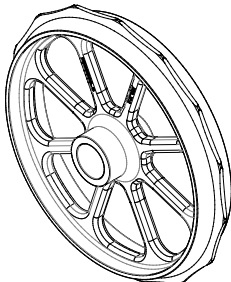
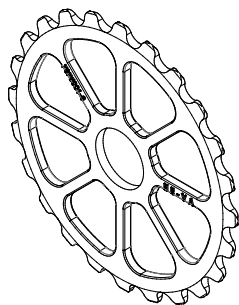

Ring types:

Cambridge rings Ø510 mm with 8 spokes		Designation	Quality	Item no.
		Pos. 8 Hub 104 mm	GG25	7375003
		Pos. 8 Hub 104 mm	GGG50	7375010
		Pos. 8 Hub 80 mm	GG25	7375004
		Pos. 8 Hub 80 mm	GGG50	7375008
		Pos. 8 Hub 72 mm w/bearing	GGG50	7375025
		Pos. 8 Hub 82 mm w/bearing	GGG50	7375026
		Pos. 7	GG25	7375001
Pos. 7	GGG50	7375013		
Pos. 8 510 mm Plain ring (8 spokes)	Pos. 7 510 mm Serrated ring (8 spokes)			

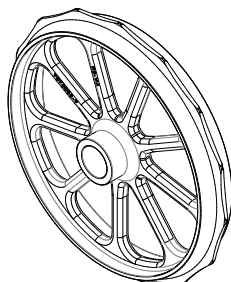
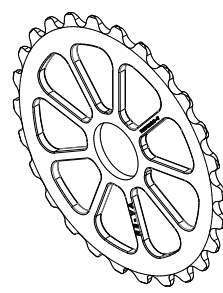
Cambridge rings Ø560 mm with 9 spokes		Designation	Quality	Item no.
		Pos. 8 Hub 104 mm	GG25	7375005
		Pos. 8 Hub 104 mm	GGG50	7375009
		Pos. 8 Hub 80 mm	GG25	7375007
		Pos. 8 Hub 80 mm	GGG50	7375011
		Pos. 8 Hub 72 mm w/bearing	GGG50	7375023
		Pos. 8 Hub 82 mm w/bearing	GGG50	7375024
		Pos. 7	GG25	7375000
Pos. 7	GGG50	7375012		
Pos. 8 560 mm Plain ring (9 spokes)	Pos. 7 560 mm Serrated ring (9 spokes)			

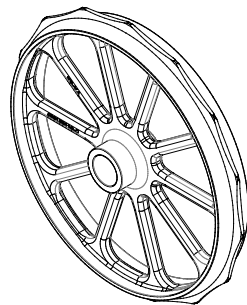
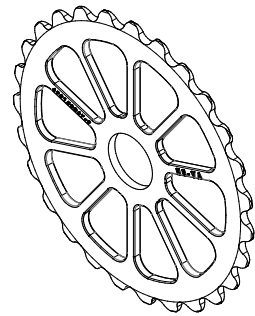

Cambridge rings Ø620 mm with 10 spokes		Designation	Quality	Item no.
		Pos. 8 Hub 104 mm	GG25	690150113
		Pos. 8 Hub 104 mm	GGG50	7375016
		Pos. 8 Hub 80 mm	GG25	690150111
		Pos. 8 Hub 80 mm	GGG50	7375015
		Pos. 8 Hub 72 mm w/bearing	GGG50	7375021
		Pos. 8 Hub 82 mm w/bearing	GGG50	7375022
		Pos. 7	GG25	690150067
Pos. 7	GGG50	690150116		
Pos. 8 620 mm Plain ring (10 spokes)	Pos. 7 620 mm Serrated ring (10 spokes)	Not an option on 20,3m		

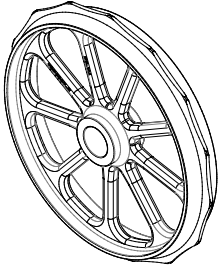

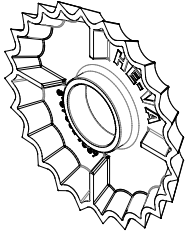
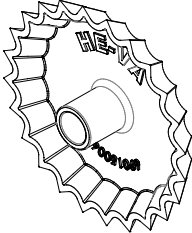
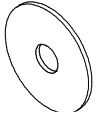
2D Corrugated ring	Designation	Quality	Item no.
	Pos. 11A Ø500	GG25	7375004
	Pos. 11B Ø550	GG25	7375007
	Pos. 11C Ø600	GG25	690150111
	Pos. 11A Ø500 Hub 67 mm w/bearing	GGG50	7375049
	Pos. 11A Ø500 Hub 72mm w/bearing	GGG50	7375025
	Pos. 11B Ø550 Hub 67mm w/bearing	GGG50	7375050
	Pos. 11B Ø550 Hub 72 mm w/bearing	GGG50	7375023
	Pos. 11C Ø600 Hub 67mm w/bearing	GGG50	7375051
	Pos. 11C Ø600 Hub 72 mm w/bearing	GGG50	7375021
Pos. 11A – 11B – 11C Corrugated ring (8-9-10 spokes)	Ø600 not an option on 20,3m		

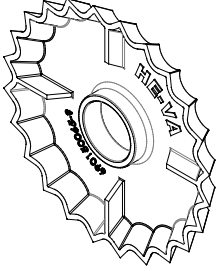
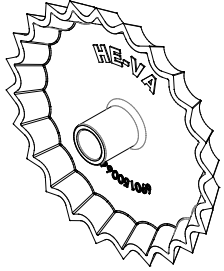
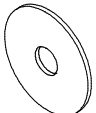
Starrings Ø450/Ø500 mm			Designation	Quality	Item no.
			Pos. 10A Ø500/Ø135	GGG50	690150063
			Pos. 10B Ø485	GGG50	690150064
			Pos. X Mountingplate		690150112
Pos. 10A 500 mm	Pos. 10B 450 mm	Pos. X 235 mm			

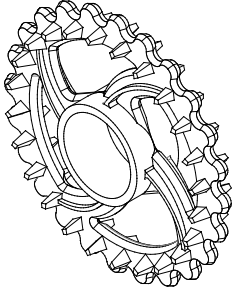
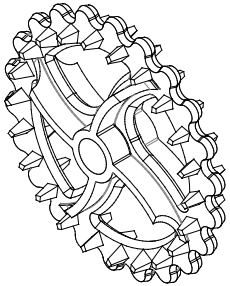
Starrings Ø550/Ø600 mm			Designation	Quality	Item no.
			Pos. 10 Ø600/Ø135	GGG50	690150065
			Pos. 11 Ø550	GGG50	690150066
			Pos. X Mountingplate		690150112
Pos. 10C 600 mm	Pos. 10D 550 mm	Pos. X 235 mm	Not an option on 20,3m		

Crosskill 485/530 mm – 550/600 mm			Designation	Quality	Item no.
			Pos. 14 530 mm	GG25	690150011
			Pos. 14 485 mm	GG25	690150034
			Pos. 14 600 mm	GG25	690150075
			Pos. 14 550 mm	GG25	690150074
			Pos. 15 Hub Ø104		690150076
Pos. 14 Loose Crosskill	Pos. 14 Tight Crosskill	Pos. 15 Hub	550/600 not an option on 20,3m		

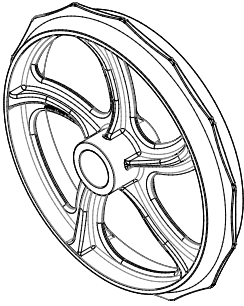
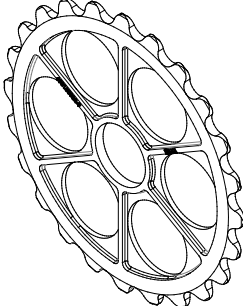
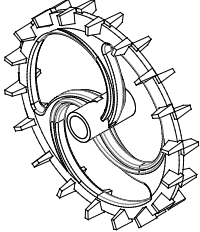
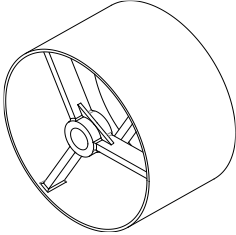
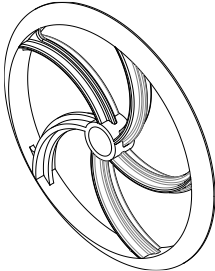
Cambridge ringe Ø510 mm with 5 spokes		Designation	Quality	Item no.
		Hub 104 mm	GG25	690150103
		Hub 80 mm	GG25	690150105
		Hub 72 mm w/bearing	GG25	630764037
		Hub 82 mm w/bearing	GG25	630764034
		Pos. X		690150032
Ended				
510 mm Plain ring (5 spokes)	Pos. X 510 mm Serrated ring			
Cam ring 550 mm		Designation	Quality	Item no.
		Hub 155 mm	GG25	690150007
Ended				
550 mm Cam ring				
Plain ring 505 mm		Designation	Quality	Item no.
				690150028
Ended				
505 mm Plainring				
Corrugated ring 500 mm		Designation	Quality	Item no.
				690150013
Ended				
Corrugated ring Ø500				

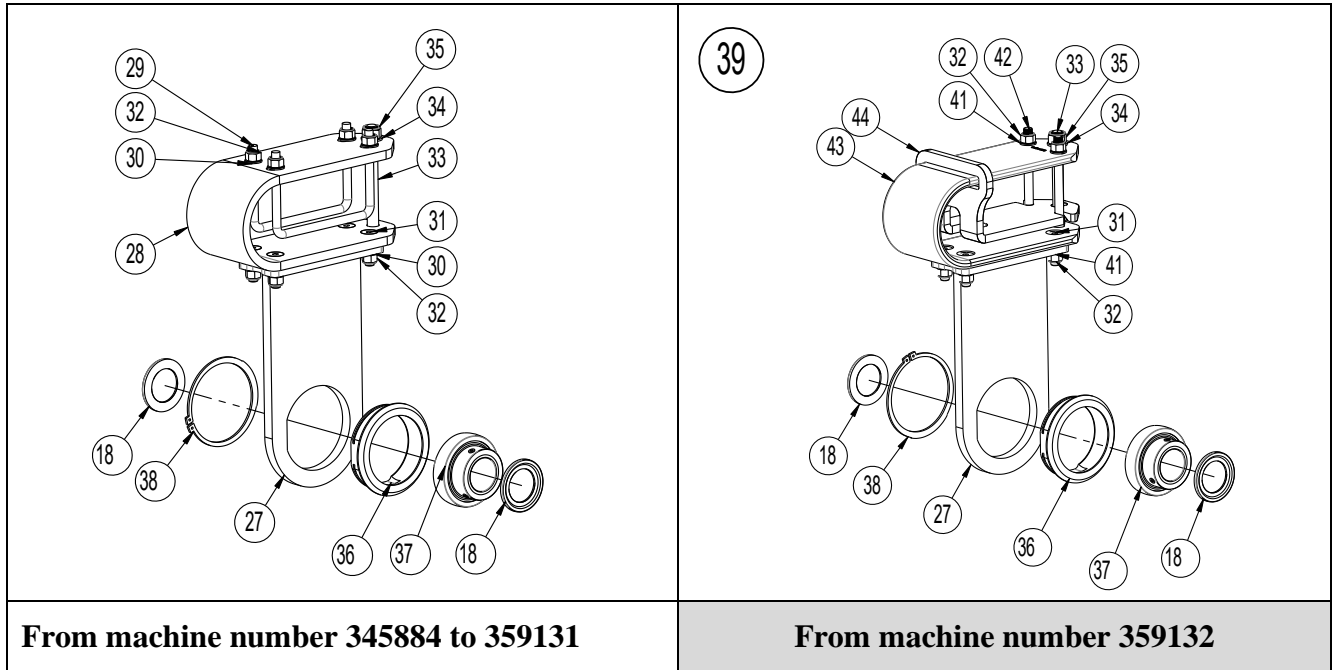
Support bearing:

From machine number 345884 to 359131
From machine number 359132
From machine number 345884 to 359131 inclusive

Pos.	Itemnumber	Designation	Per Support bearing
18	7355000	Thrust plate, narrow f/ UCF312 hub	2
27	630670570	Bracket for support bearing	1
28	630670617	Spring	1
29	0382852	U-bolt M16x100x200x100	2
30	690117016	Hardened washer FZB Ø17x45x6	8
31	0229000	Countersunk screw M16x60 DIN 7991	4
32	0264090	Locking nut M16	8
33	690103213	Bolt M20x200 8.8	1
34	0272310	Facet plate Ø20	1
35	0264110	Locking nut M20	1
36	630764008	Bearing housing f/UC 312 bearing	1
37	690140116	Bearing UC 312 R6 (Ø60)	1
38	691370150	Seeger-circlip ring outer Ø150 DIN471	1

From machine number 359132

Pos.	Itemnumber	Designation	Per Support bearing
18	7355000	Thrust plate, narrow f/ UCF312 hub	2
27	630670570	Bracket for support bearing	1
31	0229000	Countersunk screw M16x60 DIN 7991	4
32	0264090	Locking nut M16	6
33	690103213	Bolt M20x200 8.8	1
34	0272310	Facet plate Ø20	1
35	0264110	Locking nut M20	1
36	630764008	Bearing housing f/UC 312 bearing	1
37	690140116	Bearing UC 312 R6 (Ø60)	1
38	691370150	Seeger-circlip ring outer Ø150 DIN471	1
41	0272290	Facet plate 16mm, fzb	6
42	0229030	Countersunk screw M16x160 UH DIN 7991 8.8 FZB	2
43	0431660	Spring	1
44	1225258	Bracket	1
39	63067-57	Support bearing complete	

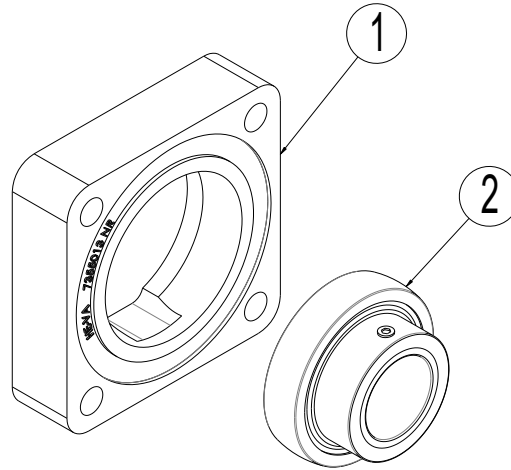

Rubberdamped bearing (additional equipment)

Pos.	Item no.	Designation	Per axle
1	7355013	Rubberdamped housing f/UC312 for axleends	2
2	690140116	Bearing UC312 R6	2

Inner wing:

Right inner wing shown, the left is laterally reversed (not shown).

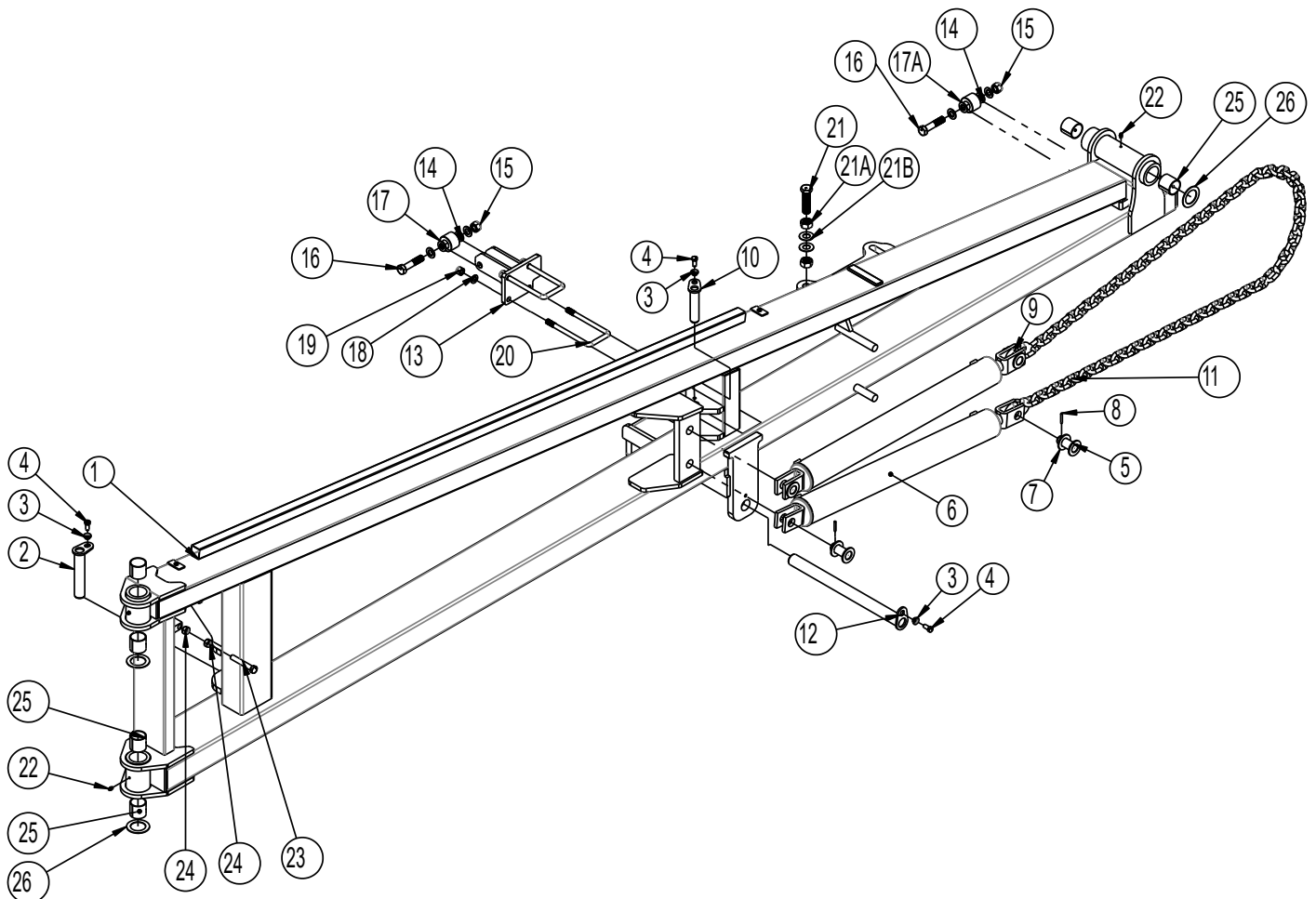

Pos.	Item no.	Designation	12,3	15,3	16,3	18,3	20,3
1	630670356	Inner wing, left 12,5m Ended					
1	630670357	Inner wing, right 12,5m Ended					
1	630670224	Inner wing, right (Low cylinder mounting) before machine no. . 345056	1				
1	630670561	Inner wing, right (High cylinder mounting) from machine no. . 345057	1				
1	630670611	Inner wing, right from machine no. . 347248	1				
1	1225016	Inner wing, right from machine no. . 349036	1				
1	630670223	Inner wing, left (Low cylinder mounting) before machine no. 345056	1				
1	630670560	Inner wing, left (High cylinder mounting) from machine no. . 345057	1				
1	630670610	Inner wing, left from machine no. . 347248	1				
1	1225015	Inner wing, left from machine no. 349036	1				
1	630670104	Inner wing, right (Low cylinder mounting) before machine no. 345056		1			
1	1225235	Inner wing, right (High cylinder mounting) from machine no. 345057		1			
1	630670105	Inner wing, left (Low cylinder mounting) before machine no. 345056		1			
1	1225236	Inner wing, left (High cylinder mounting) from machine no. . 345057		1			
1	630670536	Inner wing, right (High cylinder mounting)			1		
1	1225020	Inner wing, right from machine no. . 349036			1		
1	630670519	Inner wing, left (High cylinder mounting)			1		
1	1225019	Inner wing, left from machine no. 349036			1		
1	630670531	Inner wing, right (High cylinder mounting)				1	
1	1225018	Inner wing, right from machine no. . 349036				1	
1	630670451	Inner wing, left (High cylinder mounting)				1	
1	1225017	Inner wing, left from machine no. 349036				1	
1	630670635	Inner wing, left (High cylinder mounting)					1
	1225022	Inner wing, left from machine no. 349036					1
1	630670641	Inner wing, right (High cylinder mounting)					1
1	1225121	Inner wing, right from machine no. 349036					1
2	69435185G	Pin Ø35L=185	2	2	2	2	2
3	630532600	Lock bush for pin head	4	4	4	4	4
4	690101101	Bolt M12x25 8.8 w/glue	4	4	4	4	4
5	69530060F	Pin Ø30 L=58	8	8	8	8	8
6	690200190	Cylinder 90/40 x800, Inner wing, right	2	2			
6	690200115	Cylinder 90/40 x800, Inner wing, left	2	2			



Pos.	Item no.	Designation	12,3	15,3	16,3	18,3	20,3
6a	690200268	Gasket set for 90/40 cylinder (Klinkby)					
6b	690200274	Gasket set for 90/40 (Laizhou)					
6	690200325	Cylinder 100/40 x 1100, right			2	2	
6	690200335	Cylinder 100/40 x 1100, left			2	2	
6a	690200290	Gasket set 100/40 (Hydraflex)					
6b	690200295	Gasket set 100/40 (Laizhou)					
6	690200226	Cylinder 110/50 x 1100, H					2
6a	690200336	Cylinder 110/50 x 1100, V					2
6b	690200313	Gasket set 110/50 (Hydraflex)					
7	690115014	Facet plate Ø30	8	8	8	8	8
8	690130132	Roll pin ø6x40mm	8	8	8	8	8
9	630670260	Connecting link 13mm	4	4	4	4	4
9	1225296	Connecting link 16mm From machinno. 358659			4	4	4
10	69430130G	Pin Ø30 L=130	2	2			
10	69435120G	Pin Ø35 L=120			2	2	2
11	630670261	Chain for wing Lower	2	2			
11a	630670266	Chain for wing Upper	2	2			
11	630670318	Chain for wing Lower			2	2	
11a	630670319	Chain for wing Upper			2	2	
11	630670642	Chain for wing Lower					2
11a	630670643	Chain for wing Upper					2
11	1225308	Chain for wing Lower 16x48mm 27 links From machinno. 358659			2	2	2
11a	1225307	Chain for wing Upper 16x48mm 29 links From machinno. 358659			2	2	2
12	69440525G	Pin Ø40 L=525	2	2	2	2	2
13	630670258	Gripping bracket for locking claw, right	1	1	1	1	1
13	630670259	Gripping bracket for locking claw, left	1	1	1	1	1
14	690117005	Facet plate Ø20	16	16	16	16	16
15	690113009	Self-locking nut M20	8	8	8	8	8
16	690103151	Bolt M20x90 10.9	2	2	2	2	2
16A	0236211	Bolt M20x120 10.9	2	2	2	2	2
17	630670502	Roll Ø20,5 x Ø56 L=30	2	2	2	2	2
17A	630670593	Roll Ø20,5xØ56 L=51					
18	690117013	Facet plate Ø16	8	8	8	8	8
19	690113008	Self-locking nut M16	8	8	8	8	8
20	690110402	U-bolt M16x160x80x160	4	4	4	4	4
21	690103186	Bolt M20x110 10.9	4	4	4	4	4
21	0236432	Bolt M24x 90 8.8 From machinno. 358659			4	4	4
21a	0261425	Nut M24 (galvanized) From machinno. 358659			8	8	8
21b	0271650	Plate 24mm fzb From machinno. 358659			8	8	8
22	690136029	Lubricating nipple M8	6	6	6	6	6
23	690103284	Bolt M16x100 8.8	2	2	2	2	2
24	690112005	Nut M16	4	4	4	4	4
25	690140710	Bearing bush Ø55/50 L=50 Before machine no. 349036	12	12	12	12	12
25	0475400	Bearing bush EG Ø60/50 L=50mm From machine no. 349036	12	12	12	12	12
26	690140712	Sliding disc Ø52/Ø78x2	6	6	6	6	6



Stabilizer bar 15.3m

Left shown, the right is laterally reversed (not shown).

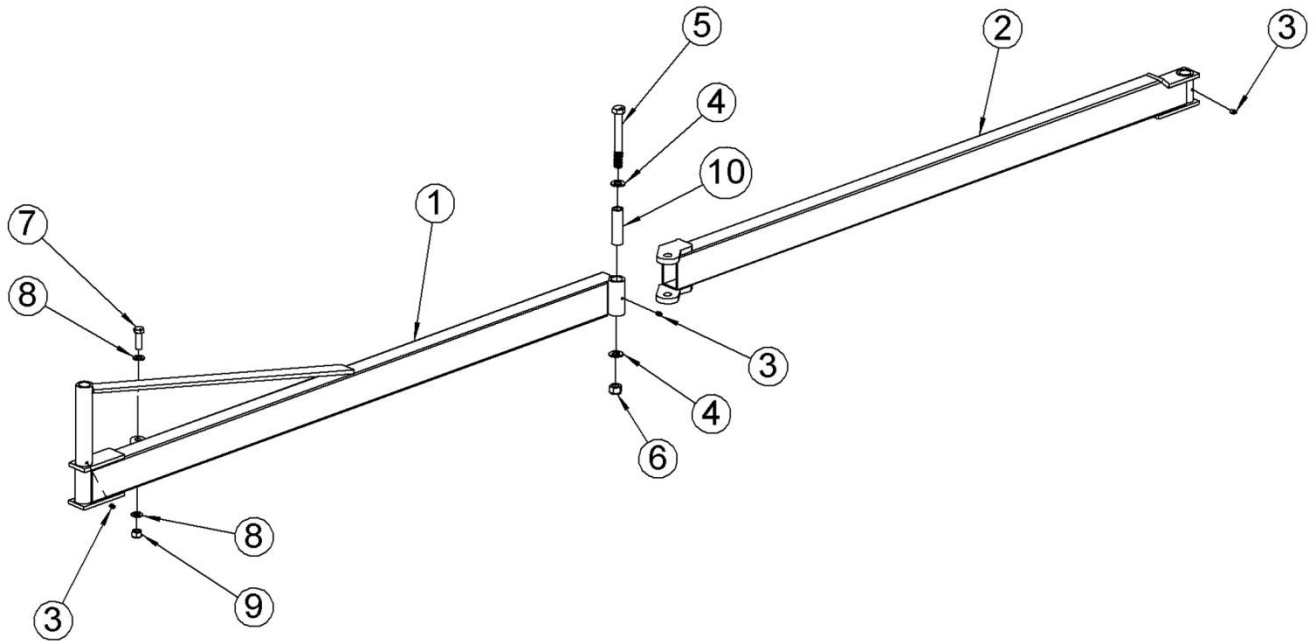

Pos.	Item no.	Designation	15.3m
1	630670181	Stabilizer bar on chassis, left	1
2	630670182	Stabilizer bar on inner wing left	1
1	630670179	Stabilizer bar on chassis, right	1
2	630670180	Stabilizer bar on inner wing, right	1
3	690136029	Lubricating nipple M8	6
4	690117005	Facet plate Ø20	4
5	690103188	Bolt M20x160 8.8	2
6	690113009	Self-locking nut M20	2
7	690103197	Bolt M16x50 8.8	2
8	690117013	Facet plate Ø16	4
9	690113008	Self-locking nut M16	2
10	630670282	BK-tube 30x5 L=100	2

Stabilizer bar 16.3m - 18,3m – 20,3m

Left shown, the right is laterally reversed (not shown).

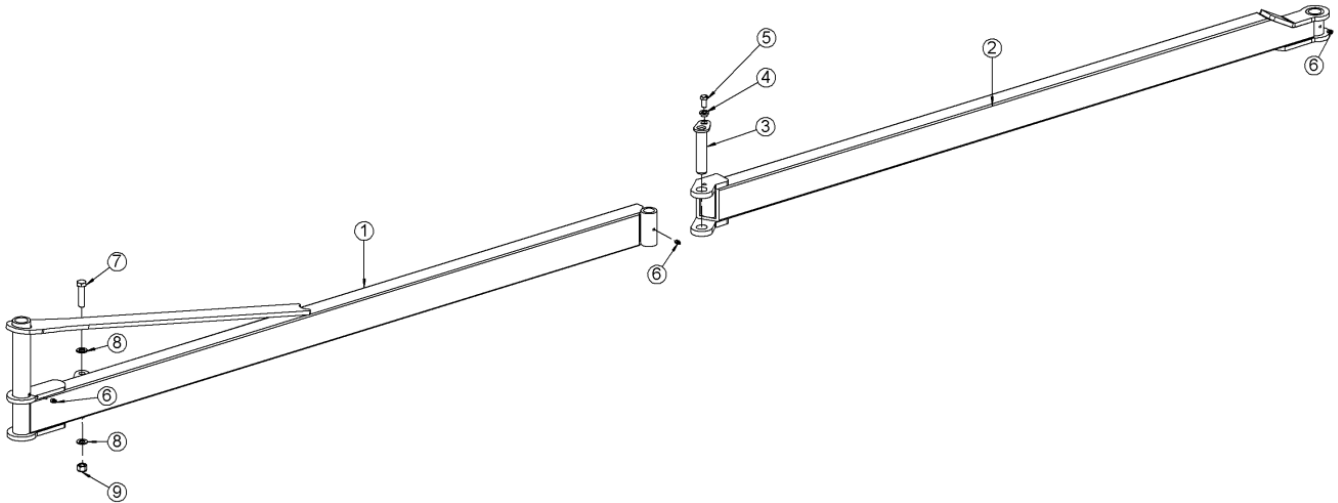

Pos	Item no.	Designation	16,3m	18,3m	20,3m
1	630670468	Stabilizer bar on chassis, left	1	1	1
2	630670462	Stabilizer bar on inner wing left	1	1	1
1	630670525	Stabilizer bar on chassis, right	1	1	1
2	630670526	Stabilizer bar on inner wing, right	1	1	1
3	69435130G	Pin Ø35 L=130	2	2	2
4	690532600	Lock bush for pin head	2	2	2
5	690101101	Bolt M12x25 8.8	2	2	2
6	690136029	Lubricating nipple M8	6	6	6
7	690113008	Bolt M16x65 8.8	2	2	2
8	690117013	Facet plate Ø16	4	4	4
9	690113008	Self-locking nut M16	2	2	2

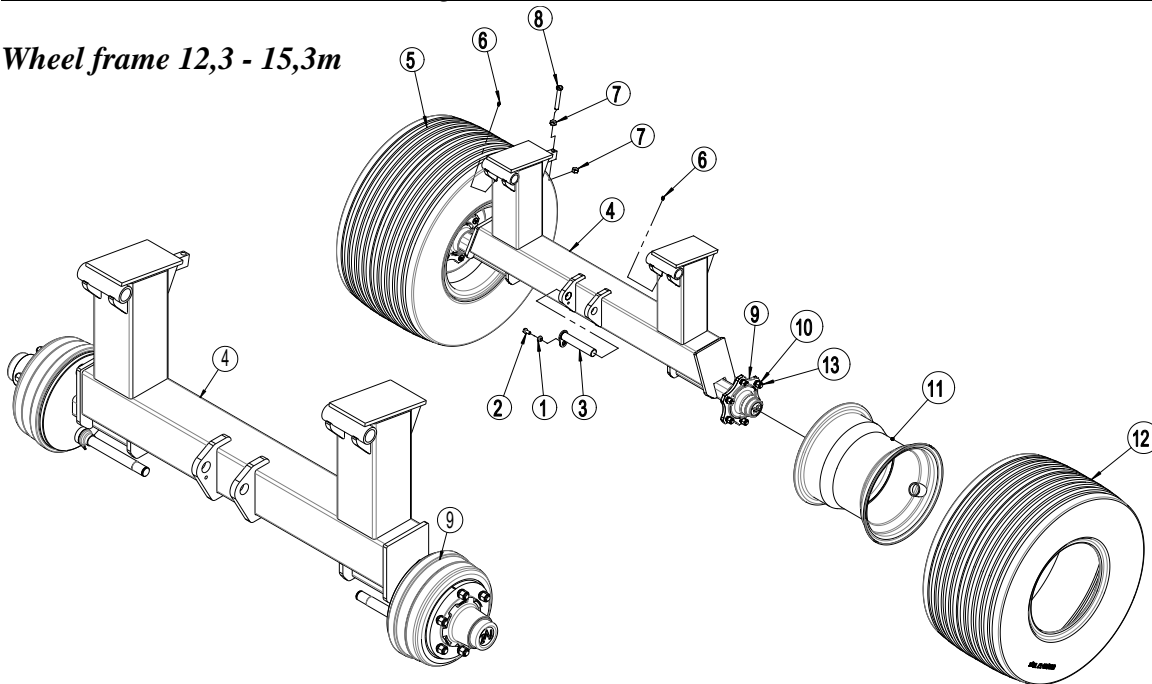
Wheel frame 12,3 - 15,3m

Pos.	Item no.	Designation	12.3m	15.3m
1	630532600	Lock bush for pin head	1	1
2	690101101	Bolt M12x25 8.8	1	1
3	69435185G	Pin Ø35 L=185	1	1
4	630670087	Wheel frame	1	1
4	630670579	Wheel frame from machine no. 345056	1	1
4	630670338	Wheel frame w/hydraulic brake	1	1
4	630670577	Wheel frame w/hydraulic brake from machine no. 345056	1	1
5	690141360	Wheel complete 500/50-17 Right before machine no. 353495	1	1
5	690141362	Wheel complete 500/50-17 Left before machine no. 353495	1	1
5	690141070	Wheel complete 550/45-22,5 Left from machine number 353495 and before as optional	1	1
5	690141071	Wheel complete 550/45-22,5 Right from machine number 353495 and before as optional	1	1
6	690136029	Lubricating nipple M8	2	2
7	690112005	Nut M16	2	2
8	690103284	Bolt M16x100 8.8	1	1
9	690141110	Hub 3500 kg 6-160-205	2	2
13	690141039	Hub bolt M18 x 1,5 x 49	12	12
9	690141032	Hub with brake 3750 kg TVZ 300Gx90	Ended	2
9	7297579	Hub with brake 3700 kg TVZ	From May 2021	2
13	690141042	Hub bolt M18 x 1,5 x 60	12	12
10	690141055	Hub nut M18x1,5	12	12
11	690141361	Wheel rim 500x17	before machine no. 353495	2
11	690141068	Wheel rim 550x22,5 from machine number 353495 and before as optional	2	2
12	690141352	Tyre 500/50x17	before machine no. 353495	2
12	690141069	Tyre 550/45x22,5 from machine number 353495 and before as optional	2	2
14	690141033	Hub cover Ø80	12	12
14	690141034	Hub Cover Ø90	2	2

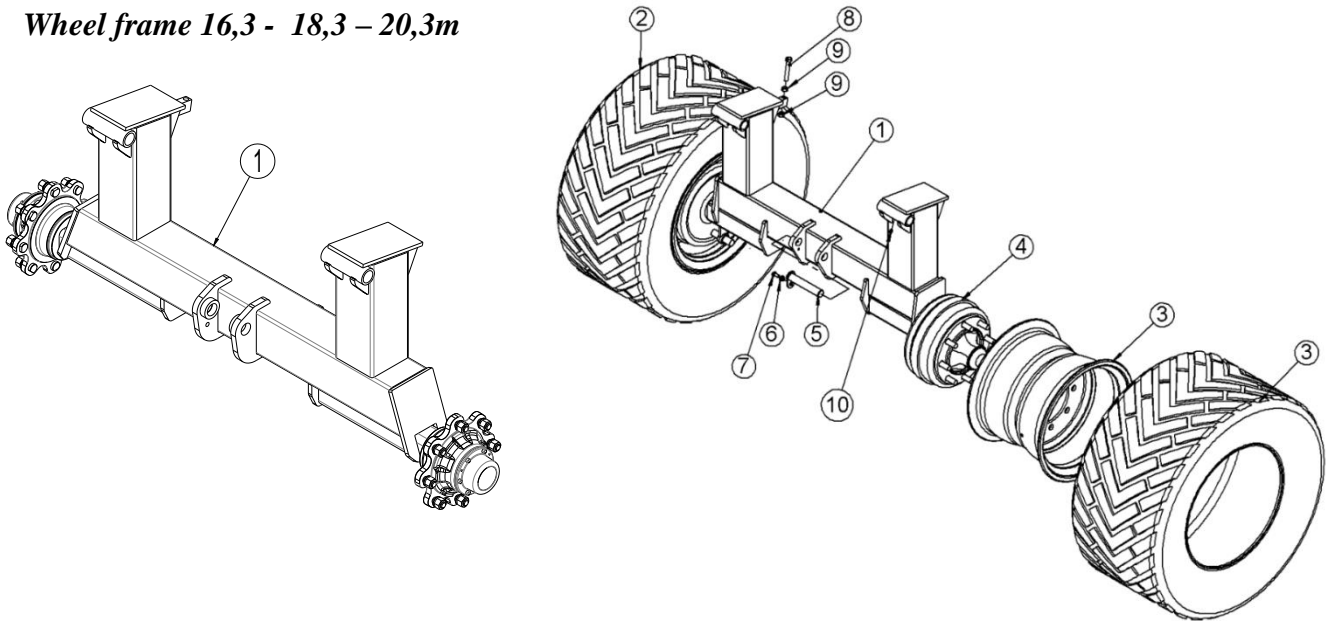

Wheel frame 16,3 - 18,3 – 20,3m

Pos	Item no.	Designation	16,3	18,3	20,3
1	1225316	Wheel frame	1	1	1
1	630670461	Wheel frame w/ brake (5000kg)	1	1	1
1	630670644	Wheel frame w/ brake (6000kg) From oct 2013	1	1	1
1	1225005	Wheel frame w/ (6000kg) After machinnr. 347462	1	1	1
2	690141053	Complete Wheel, left	1	1	1
2a	690141051	Wheel rim 16,00x22,5 : 8/M27 221 275	1	1	1
2b	690141052	Tyre 560/45 R22,5 FL 693 : Dia=1076 Bredde=543	1	1	1
3	690141054	Complete Wheel, right	1	1	1
3a	690141051	Wheel rim 16,00x22,5 : 8/M27 221 275	1	1	1
3b	690141052	Tyre 560/45 R22,5 FL 693 : Dia=1076 Bredde=543	1	1	1
4	0396800	Hub axle 90x90mm 5250 kg	2	2	2
4	690141050	Hub w/brake 5000 kg axle 90x90mm Q90x370 350Gx100IHC 8 B90H0021	2	2	2
4	690141160	Hub w/brake 6000 kg From oct 2013 Q90x415 400Gx80 8 B90L127	2	2	2
4a	690141049	Hub bolt M22x1,5	16	16	16
4a	0396860	Hub bolt M20x1.5 L=65mm f/0396800	16	16	16
4b	690141048	Hub nut M22x1,5 incl. spring washer	16	16	16
4b	0396870	Nav nut M20x1,5 CH30 f/0396800	16	16	16
4c	690141047	Hub cover Ø100	2	2	2
4c	690141162	Hub cover Ø150 mounted w/M6 bolts	2	2	2
4c	0396894	Hub cover f/0396800	2	2	2
5	69435185G	Pin Ø35 L=185	1	1	1
5a	69440200N	Pin Ø40 L=200 after machinnr. 347462	1	1	1
6	630532600	Lock bush for pin head	1	1	1
6a	630532700	Lock bush for pin head after machinnr. 347462	1	1	1
7	690101101	Bolt M12x25 8.8	1	1	1
7a	690103198	Bolt M16x30 8.8 after machinnr. 347462	1	1	1
8	690103284	Bolt M16x100 8.8	1	1	1
9	690136029	Lubricating nipple M8	2	2	2
10	690112005	Nut M16	2	2	2

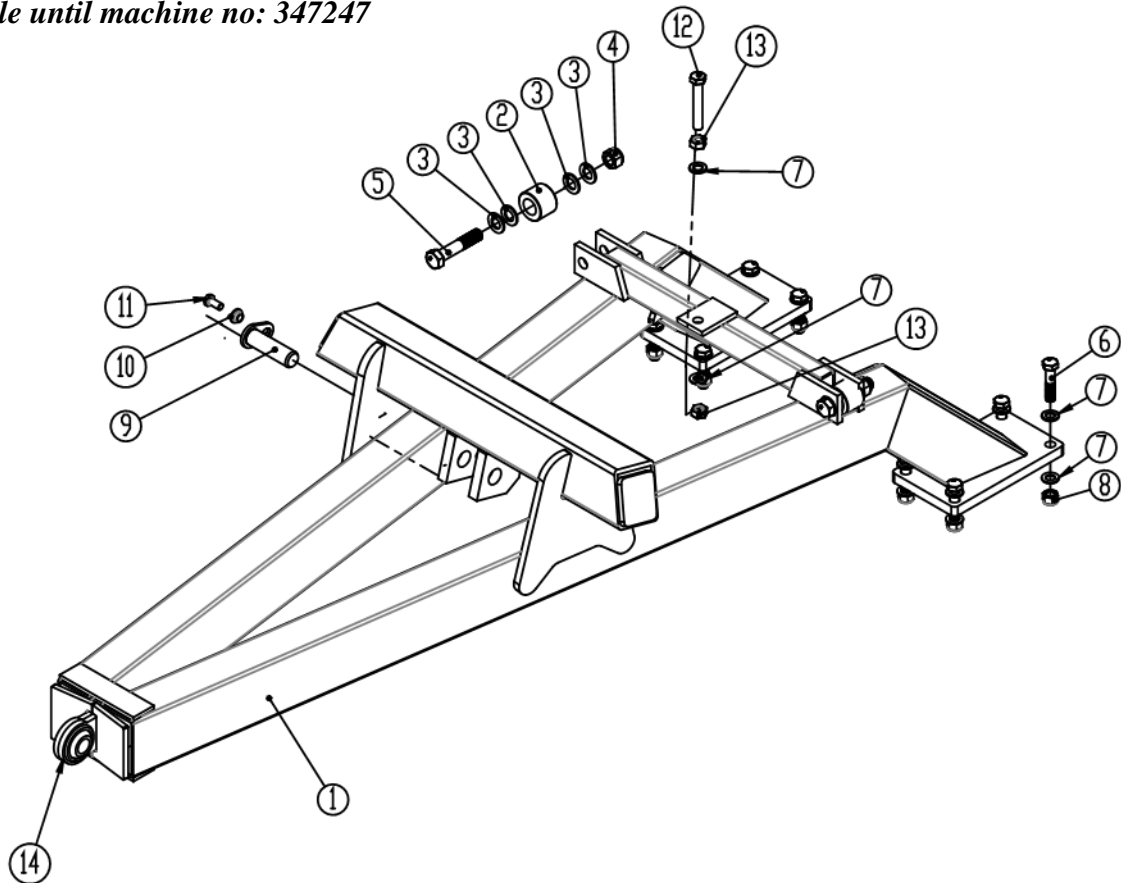

Triangle until machine no: 347247

Pos.	Item no.	Designation	12.3	15.3	16,3	18,3	20,3
1A	630670102	Triangle (Ended)	1	1			
1B	630670324	Triangle	1	1	1	1	1
2B	630984502	Roll Ø20,5xØ56 L=30	2	2	2	2	2
1C	630670584	Triangel From machin no 346088 until 347247	1	1	1	1	1
2C	630984503	Roll Ø30,5xØ54 L=40	2	2	2	2	2
3	690117005	Facet plate Ø20	8	8	8	8	8
4	690113009	Self-locking nut M20	2	2	2	2	2
5	690103163	Bolt M20x150 8.8	2	2	2	2	2
6	690103130	Bolt M16x70 10.9	8	8	8	8	8
7	690117013	Facet plate Ø16	18	18	18	18	18
8	690113008	Self-locking nut M16	8	8	8	8	8
9	69430100G	Pin Ø30 L=100	1	1	1	1	1
10	630532600	Lock bush for pin head	1	1	1	1	1
11	690101101	Bolt M12x25 8.8	1	1	1	1	1
12B	690103188	Bolt M16x55 10.9	1	1	1	1	1
12C	690103282	Bolt M16x100 10.9	1	1	1	1	1
13	690112005	Nut M16	2	2	2	2	2
14	690302105	Ball link for welding Ø28,4 welding height = 70	1	1	1	1	1

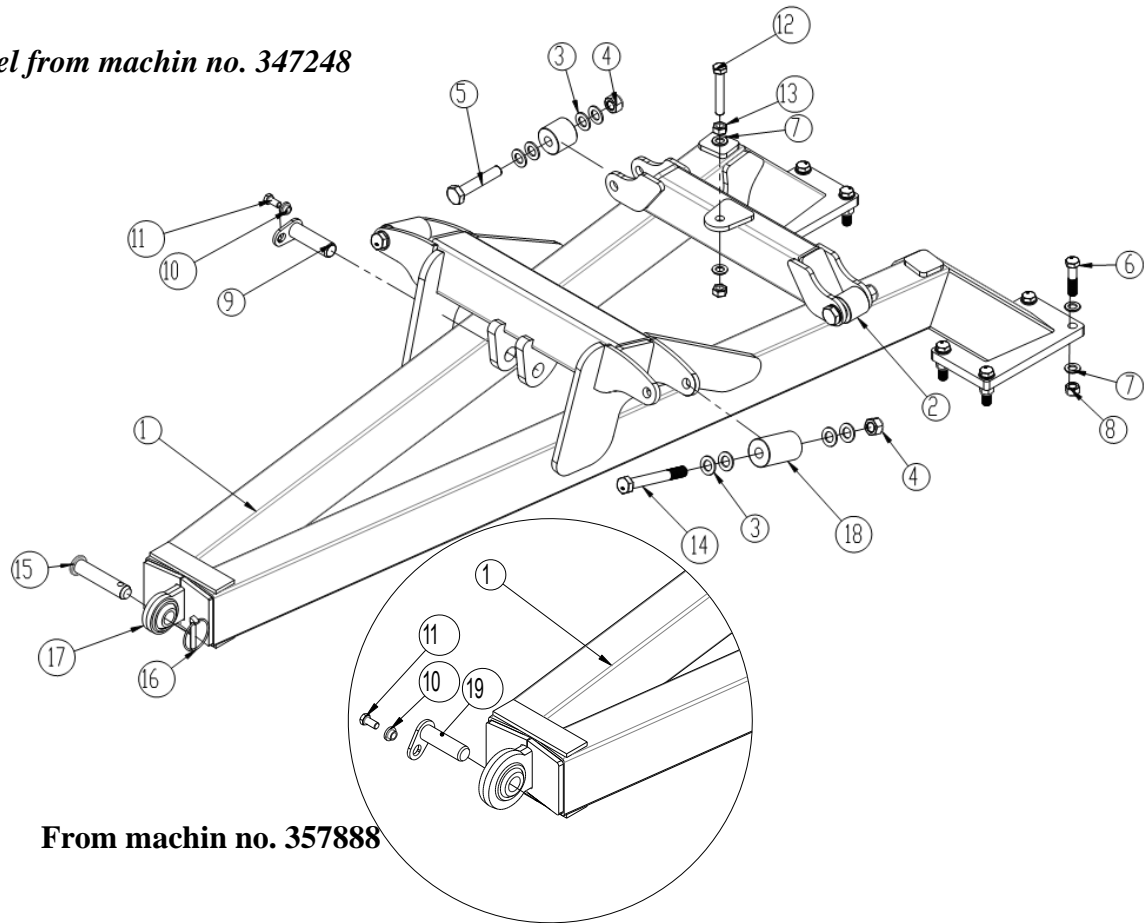

Triangel from machin no. 347248

From machin no. 357888

Pos.	Item no.	Designation	12,3	15,3	16,3	18,3	20,3
1	630670602	Triangel From machin no. 347248	1	1	1	1	1
2	630670593	Roll Ø20,5xØ56 L=51	2	2	2	2	2
3	690117005	Facet plate Ø20	16	16	16	16	16
4	690113009	Self-locking nut M20	4	4	4	4	4
5	690103196	Bolt M20x110 8.8	2	2	2	2	2
6	690103130	Bolt M16x70 10.9	8	8	8	8	8
7	690117013	Facet plate Ø16	18	18	18	18	18
8	690113008	Self-locking nut M16	8	8	8	8	8
9	69430100G	Pin Ø30 L=100	1	1	1	1	1
10	630532600	Lock bush for pin head	2	2	2	2	2
11	690101101	Bolt M12x25 8.8	2	2	2	2	2
12	690103282	Bolt M16x100 10.9	1	1	1	1	1
13	690112005	Nut M16	2	2	2	2	2
14	690103188	Bolt M20x160 8.8	2	2	2	2	2
15	69528106J	Pin Ø28 L=106	1	1	1	1	1
16	690134008	Ring Pin Ø11,5 ring Ø60	1	1	1	1	1
17	690302106	Ball link for welding Ø28,4 Welding height = 80	1	1	1	1	1
18	630670603	Roll Ø20,5 Ø56 L=93	2	2	2	2	2
19	69528095G	Pin Ø28 L=95 From machin no. 357888	1	1	1	1	1

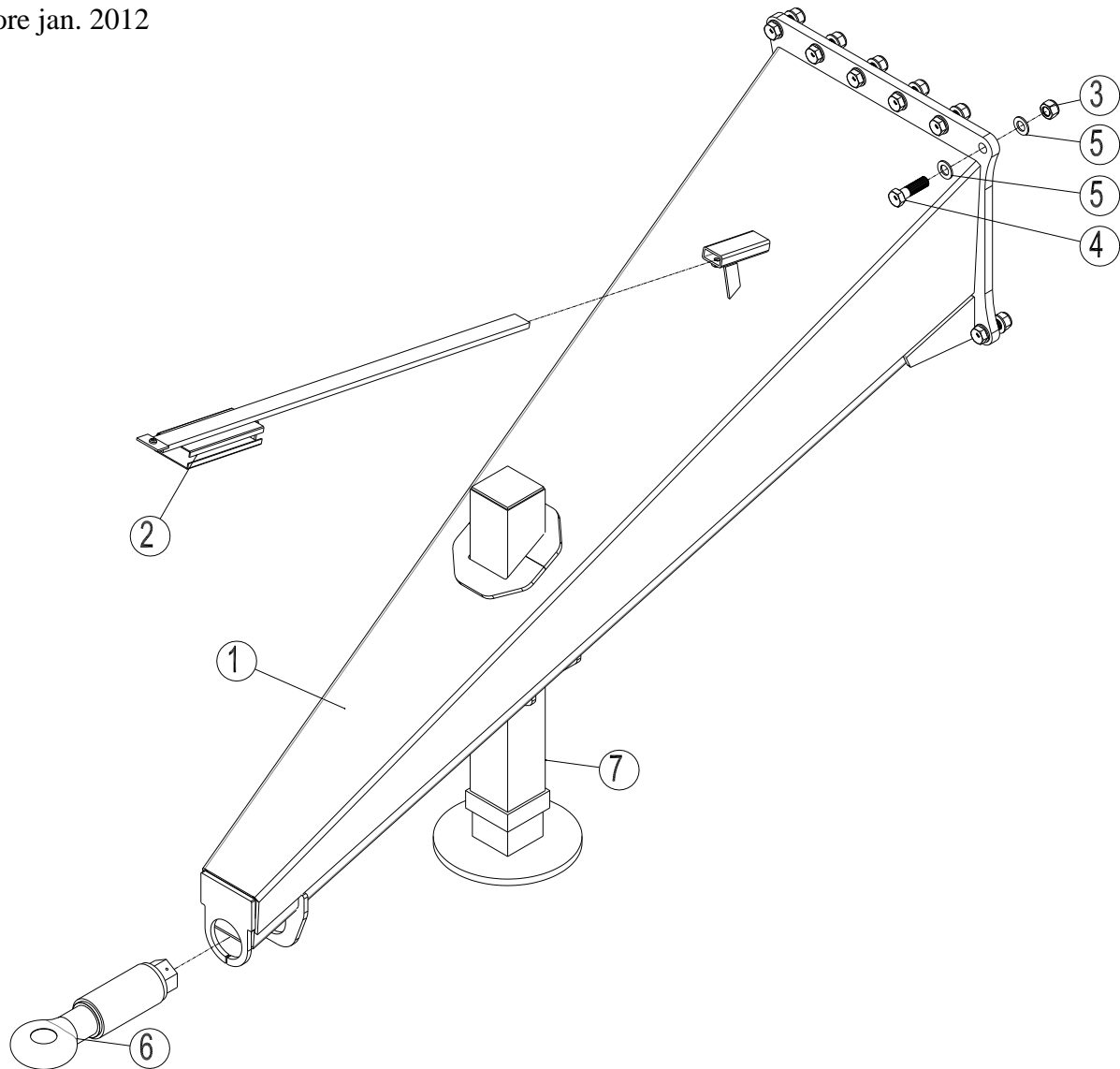

Drawbar 12,3 - 15,3m

before jan. 2012



Pos.	Item no.	Designation	12.3m	15.3m
1	630670082	Front drawbar w/centermounted supporting leg	1	1
2	630771200	Parking device for hoses	1	1
3	690113009	Self-locking nut M20	14	14
4	690103173	Bolt M20x70 10.9	14	14
5	690117005	Facet plate Ø20	28	28
6	690105010	Towing eye Ø50 35CRM04	1	1
7	690141098	Hydraulic supporting leg 4300 kg	1	1



Drawbar 12,3 - 15,3 - 16,3 - 18,3 - 20,3m,

Old design hose stand before feb. 2016

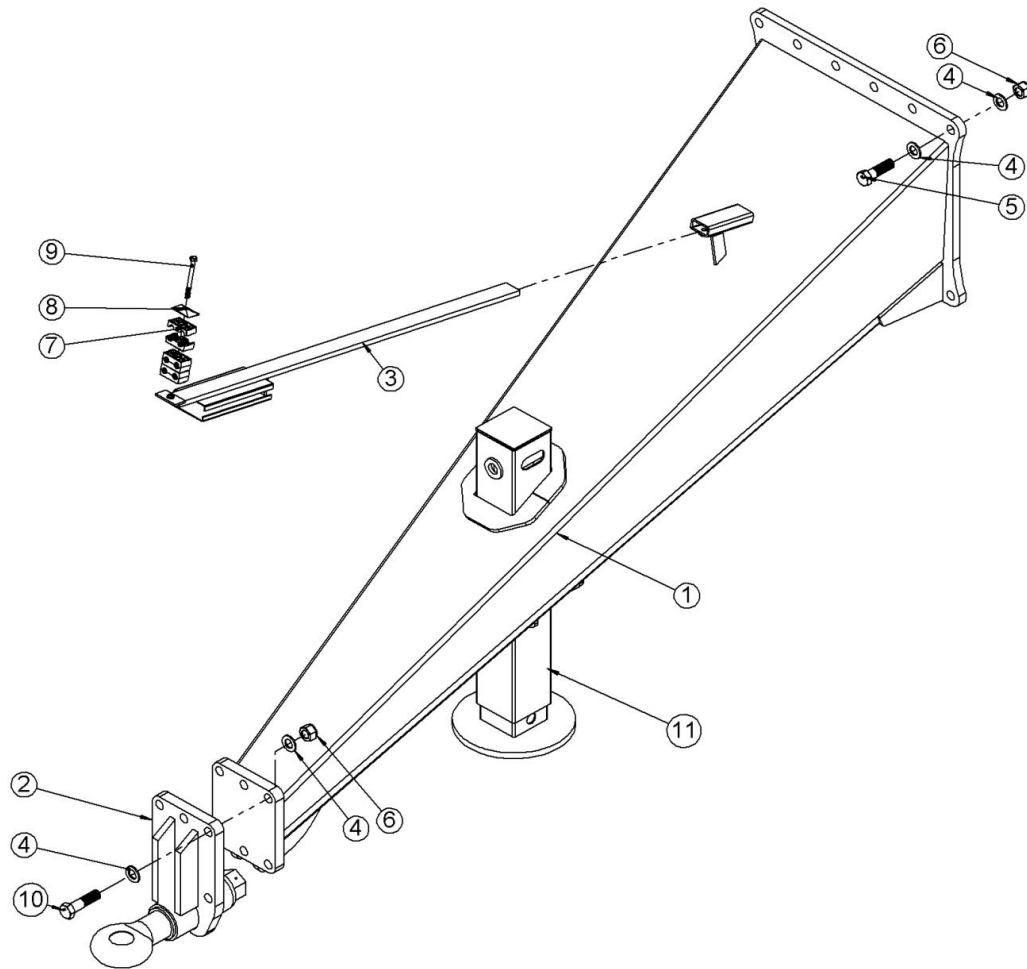

Pos.	Item no.	Designation	12,3	15,3	16,3	18,3	20,3
1	630670333	Front drawbar w/centermounted supporting leg	1	1	1	1	1
2	630757046	Complete towing eye, 35CRM04	1	1	1	1	1
2a	690105010	Towing eye Ø50 35CRM04	1	1	1	1	1
3	630771200	Parking device for hoses	1	1	1	1	1
4	690117005	Facet plate Ø20	28	28	28	28	28
5	690103173	Bolt M20x70 10.9	8	8	8	8	8
6	690113009	Self-locking nut M20	14	14	14	14	14
7	690210210	Tube support double Ø14 Ø14, green	6	6	6	6	6
8	690210211	Top plate f/tube support double	1	1	1	1	1
9	690103061	Bolt M8x90 8.8	1	1	1	1	1
10	690103069	Bolt M20x80 10.9	6	6	6	6	6
11	690141105	Hydraulic supporting leg 5772 kg v/150 bar	1	1	1	1	1



Drawbar 12,3 - 15,3 - 16,3 - 18,3 - 20,3m,

New design hose stand after feb. 2016

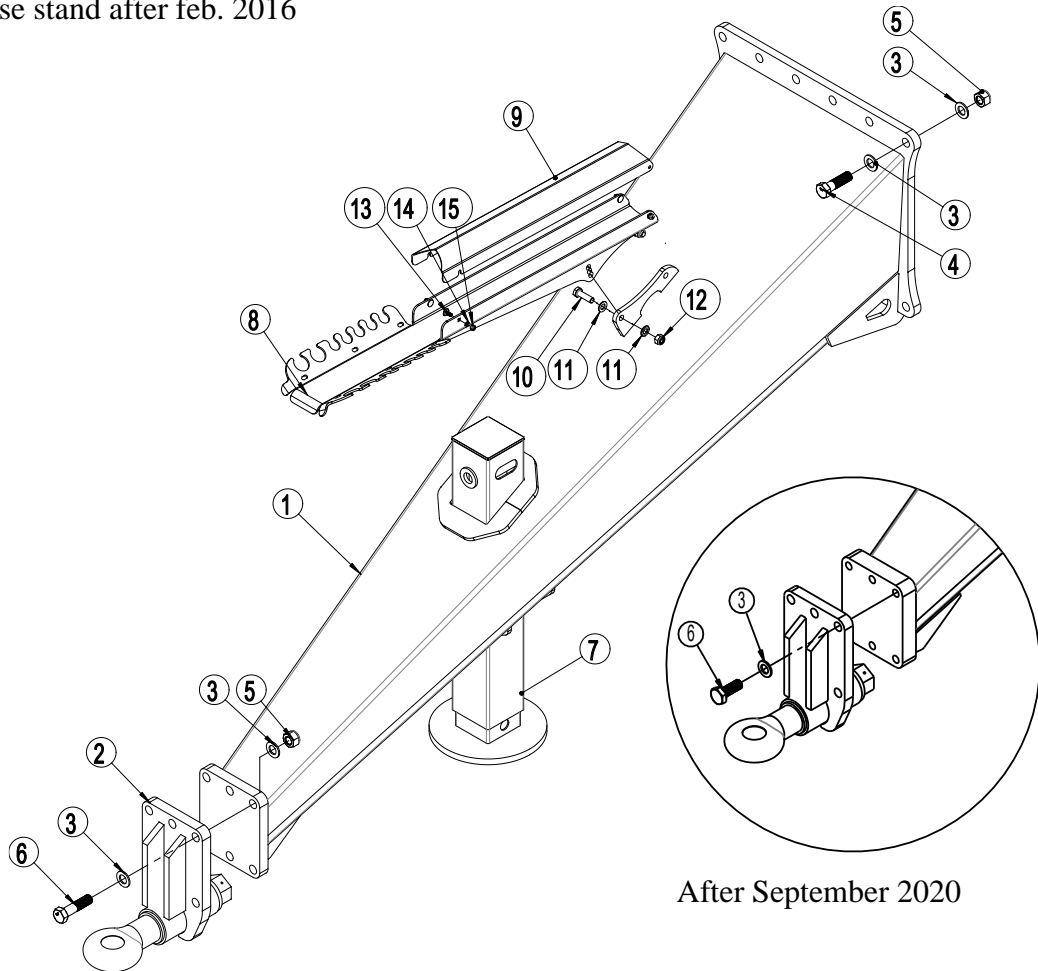

After September 2020

Pos	Item no.	Designation	12,3	15,3	16,3	18,3	20,3
1	630670349	Front drawbar w/centermounted supporting leg	1	1	1	1	1
2	630757046	Complete towing eye, 35CRM04	1	1	1	1	1
2a	690105010	Towing eye Ø50 35CRM04	1	1	1	1	1
3	0272310	Facet plate Ø20	40	40	40	40	40
4	690103173	Bolt M20x70 10.9	14	14	14	14	14
5	0264110	Self-locking nut M20	20	20	20	20	20
6	690103069	Bolt M20x80 10.9	6	6	6	6	6
6	690103182	Setbolt M20x55 10.9 After sep. 2020	6	6	6	6	6
7	690141105	Hydraulic supporting leg 5772 kg v/150 bar	1	1	1	1	1
8	7345006	Lower part for hose stand	1	1	1	1	1
8a	7345019	Hose stand, complete with bolts-plates-nuts					
9	7345003	Cover for hose stand	1	1	1	1	1
10	0235360	Setbolt M12x40 8.8	2	2	2	2	2
11	0272270	Facet plate Ø12	4	4	4	4	4
12	0264070	Self-locking nut M12 DIN985	2	2	2	2	2
13	0246060	Carriage bolt M6x16 DIN603	4	4	4	4	4
14	0272240	Facet plate Ø6	4	4	4	4	4
15	0264040	Self-locking nut M6 DIN985	4	4	4	4	4

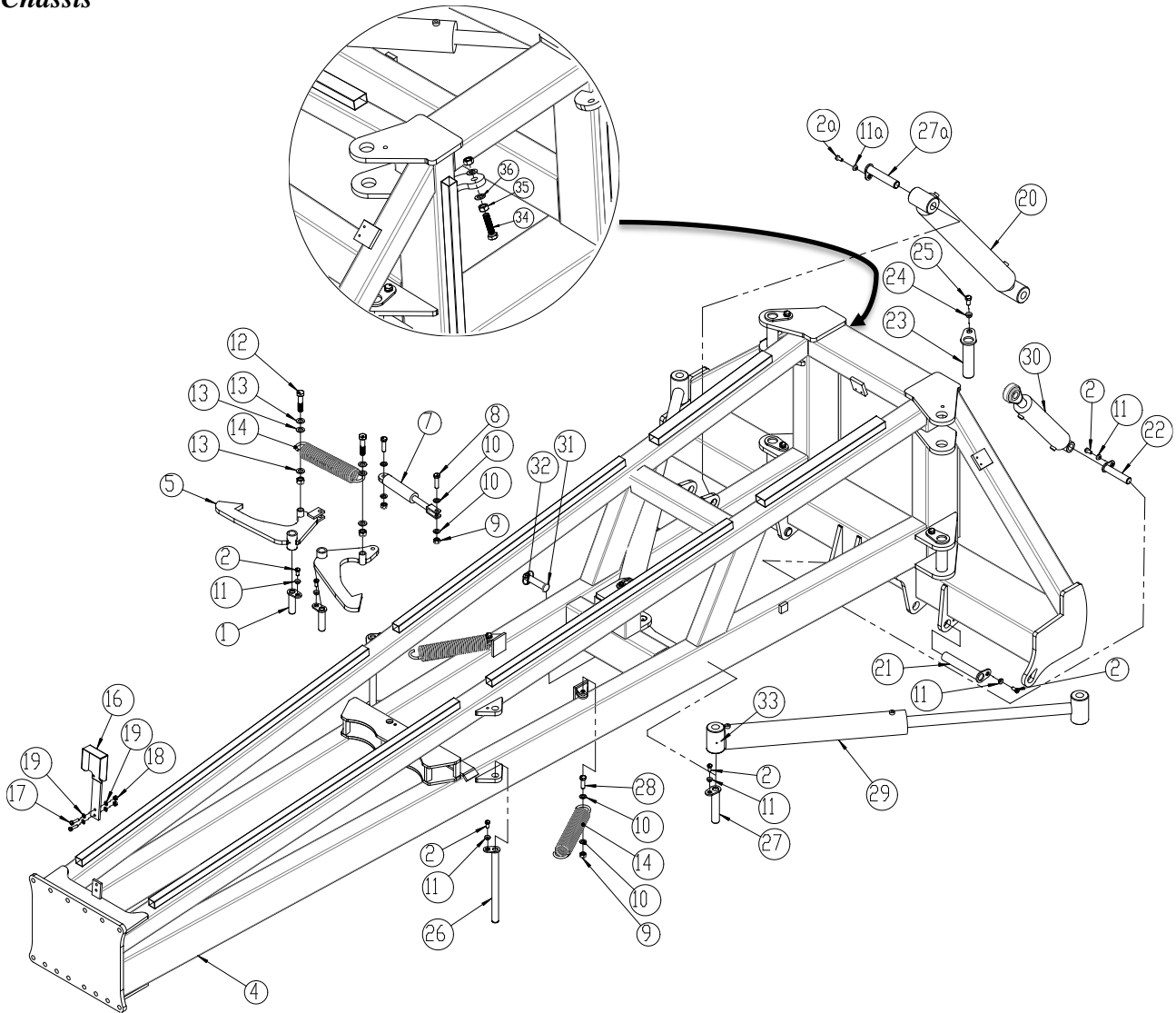

Chassis

Pos.	Item no.	Designation	12,3	15,3	16,3	18,3	20,3
1	69430110G	Pin $\varnothing 30$ L=110	2	2	2	2	2
2	690101101	Bolt M12x25 8.8	8	10	9	9	9
2a	0235770	Bolt M16x30 8.8			1	1	1
3	630670006	Bracket for locking claws	1	1	1	1	1
4	630670200	Chassis frame	1				
4	630670555	Chassis frame From machin no. 345057	1				
4	630670000	Chassis frame		1			
4	1225237	Chassis frame From machin no. 345057		1			
4	630670450	Chassis frame			1	1	
4	1225014	Chassis frame From machin no. 347462			1	1	
4	630670630	Chassis frame					1
4	1225001	Chassis frame From machin no. 347462					1
5	630670005	Locking claw – right	1	1	1	1	1
6	630670004	Locking claw – left	1	1	1	1	1
7	690200170	Cylinder 40/25x80	1	1	1	1	1



Pos.	Item no.	Designation	12,3	15,3	16,3	18,3	20,3
8	690103131	Bolt M16x60 8.8	2	2	2	2	2
9	690113008	Self-locking nut M16	2	4	4	4	4
10	690117013	Facet plate Ø16	4	8	8	8	8
11	630532600	Lock bush for pin head	8	10	9	9	9
11a	630532700	Lock bush for pin head			1	1	1
12	690103157	Bolt M20x100 8.8	2	2	2	2	2
13	690117005	Facet plate Ø20	6	6	6	6	6
14	690139001	Spring Ø60xØ10x31 turns	1	3	3	3	3
15	690113009	Self-locking nut M20	2	2	2	2	2
16	630941066	Pressure gauge housing	1	1	1	1	1
17	690103098	Bolt M10x40 8.8	2	2	2	2	2
18	690113009	Self-locking nut M10	2	2	2	2	2
19	690117012	Facet plate Ø10	4	4	4	4	4
20	690200020	Cylinder 100/50 x700 Ø35/Ø35	1	1			
20a	690200028	Gasket set 100/50					
20	690200310	Cylinder 110/50 x700 Ø35/Ø35			1	1	1
20a	690200313	Gasket set 110/50					
20	690200360	Cylinder 125/70x700 Ø40/Ø40 From machin no. 347462			1	1	1
20a	690200361	Gasket set 125/70					
21	69440230G	Pin Ø40 L=230	2	2	2	2	2
22	69430145G	Pin Ø30 L=145	1	1	1	1	1
23	69450190G	Pin Ø50 L=190	4	4	4	4	4
24	630532700	Lock bush for pin head	4	4	4	4	4
25	690103198	Bolt M16x30 8.8	4	4	4	4	4
26	69430393G	Pin Ø30 L=393	2	2			
26	69435393G	Nagle Ø35 L=393			2	2	2
27	69435185G	Pin Ø35 L=185	3	3	2	2	2
27a	69440200N	Pin Ø40 L=200			1	1	1
28	690103197	Bolt M16x50 8.8	-	2	2	2	2
29	690200029	Cylinder 100/50x700 Ø35/Ø35	2	2			
29a	690200285	Gasket set 100/50					
29	690200315	Cylinder 110/60x1000mm 35/Ø35			2	2	2
29a	690200019	Gasket set 100/60					
30	690200180	Cylinder 80x50x280	1	1	1	1	1
30a	690200145	Gasket set 80/50					
31	69528106J	Pin Ø28 L=106	1	1	1	1	1
32	695134004	Ring pin Ø10	1	1	1	1	1
33	690136029	Lubricating nipple M8	2	2	2	2	2
34	690103199	Bolt M20x80 10.9 (set bolt)	2	2	2	2	2
35	690112009	Nut M20	4	4	4	4	4
36	690117005	Facet plate Ø20	4	4	4	4	4



Outer wing

The left outer wing shown,
the right is laterally reversed (not shown).

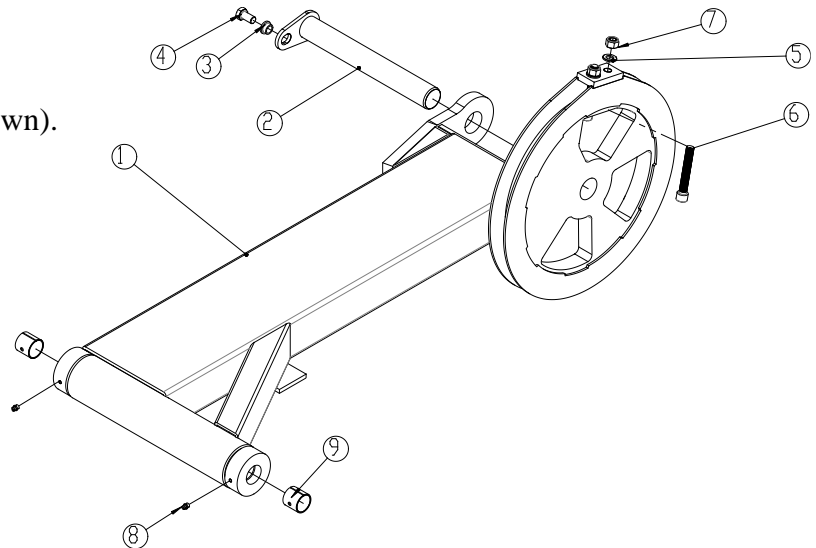

Pos	Item no.	Designation	12,3	15,3	16,3	18,3	20,3
1	630670549	Outer wing , right	1				
1	630670548	Outer wing, left	1				
1	630670197	Outer wing, right (Discontinued 12,5m)					
1	630670198	Outer wing, left (Discontinued 12,5m)					
1	630670162	Outer wing, right (Ended)		1			
1	630670163	Outer wing, left (Ended)		1			
1	630670350	Outer wing, left from jan 2012		1			
1	630670529	Outer wing, right from jan 2012		1			
1	630670537	Outer wing, right (Ended)			1		
1	1225313	Outer wing, right from machinno. 358659			1		
1	630670515	Outer wing, left (Ended)			1		
1	1225312	Outer wing, left from machinno. 358659			1		
1	630670528	Outer wing, right (Ended)				1	
1	1225297	Outer wing, right from machinno. 358659				1	
1	630670458	Outer wing, left (Ended)				1	
1	1225290	Outer wing, left from machinno. 358659				1	
1	630670625	Outer wing, right (Ended)					1
1	1225309	Outer wing, right from machinno. 358659					1
1	630670626	Outer wing, left (Ended)					1
1	1225310	Outer wing, left from machinno. 358659					1
2	69450358G	Pin Ø50 L=358 (Ended)	2	2			
2	69450375G	Pin Ø50 L=375	2	2	2	2	2
2	69450385G	Pin Ø50 L=385 from machinno. 358659			2	2	2
3	630532700	Locking bushing for pinhead	2	2	2	2	2
4	690103124	Bolt M16x35 8.8 (setbolt)	2	2	2	2	2
5	690117013	Facetplate Ø16	8	8	8	8	8
5	0272310	Facetplate Ø20 from machinno. 358659			8	8	8
6	690103210	Bolt Hexagon M16x110 12.9	4	4			
6	690103211	Bolt Hexagon M16x140 12.9 (Ended)			4	4	4
6	690103201	Bolt Hexagon M20x150 12.9 from machinno. 358659			4	4	4
7	690113008	Self-locking nut M16	4	4	4	4	4
7	0264110	Self-locking nut M20 from machinno. 358659			4	4	4
8	690136029	Lubricating nipple M8	4	4	4	4	4
9	690140715	Slide bushing Ø40/Ø44 L=40	4	4	4	4	4



Outer wing section

The left outer wing section shown, the right is laterally reversed (not shown).

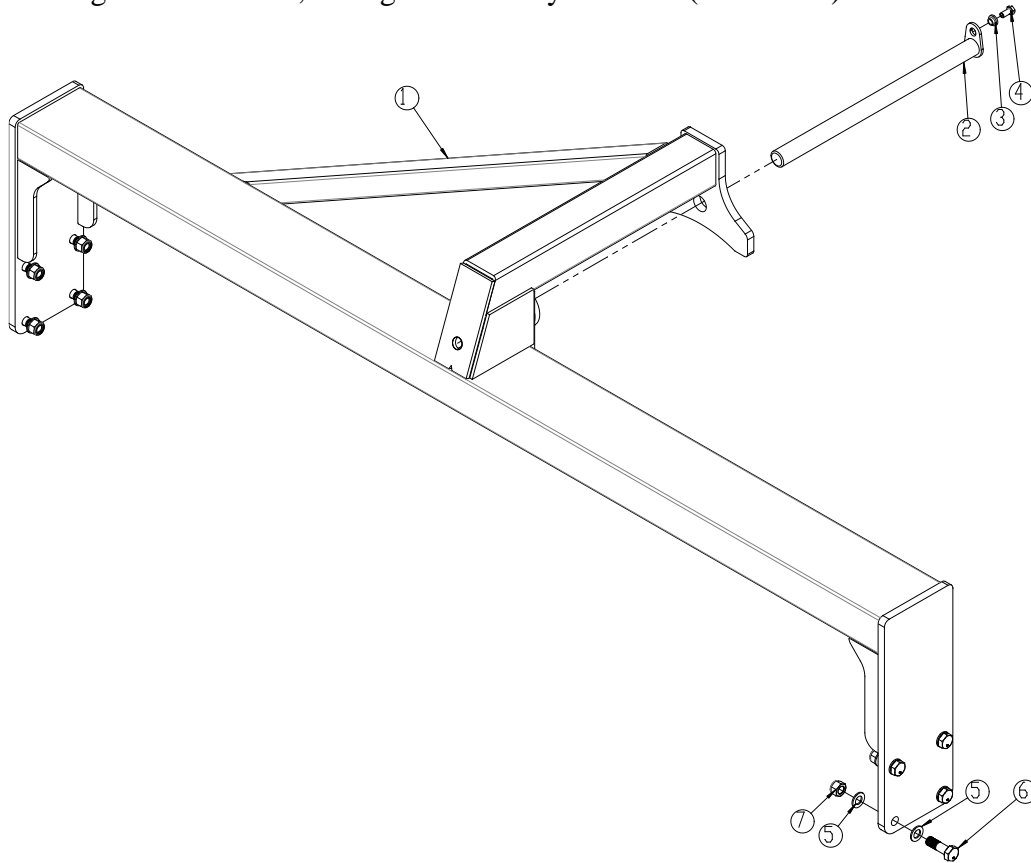

Pos	Item no.	Designation	12,3	15,3	16,3	18,3	20,3
1	630670211	Outer wing section, right (Discontinued 12,5m)					
1	630670213	Outer wing section, left (Discontinued 12,5m)					
1	630670551	Outer wing section, right	1				
1	630670552	Outer wing section, left	1				
1	630670175	Outer wing section, right		1			
1	630670176	Outer wing section, left		1			
1	630670538	Outer wing section, right			1		
1	630670517	Outer wing section, left			1		
1	630670535	Outer wing section, right				1	
1	630670290	Outer wing section, left				1	
1	630670622	Outer wing section, right					1
1	630670623	Outer wing section, left					1
2	69440620G	Pin Ø40 L=620	2	2	2	2	2
3	630532600	Lock bush for pin head	2	2	2	2	2
4	690101101	Bolt M12x25 8.8	2	2	2	2	2
5	690117005	Facet plate Ø20	16	16	16	16	16
6	690103173	Bolt M20x70 10.9	8	8	8	8	8
7	690113009	Self-locking nut M20	8	8	8	8	8



Inner wing section

The right inner wing section shown, the left is laterally reversed (not shown).

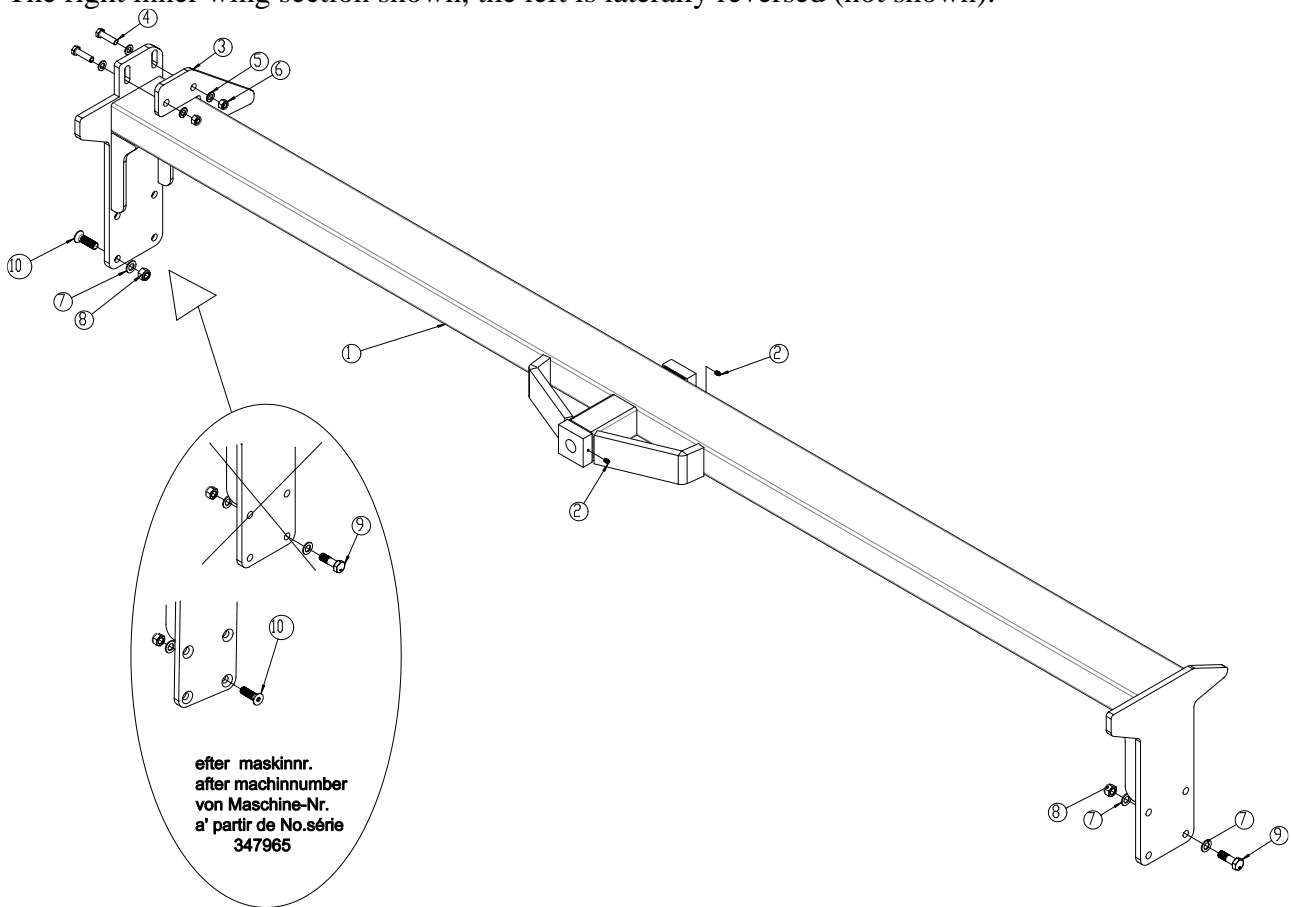

Pos	Item no.	Designation	12,3	15,3	16,3	18,3	20,3
1	630670216	Inner wing section, right	1				
1	630670214	Inner wing section, left	1				
1	630670165	Inner wing section, right		1	1	1	
1	630670164	Inner wing section, left		1	1	1	
1	630670619	Inner wing section, right					1
1	630670620	Inner wing section, left					1
2	690136029	Lubricating nipple M8	2	2	2	2	2
3	630670052	Guide for inner wing section	1	1	1	1	1
4	690103131	Bolt M16x60 8.8	2	2	2	2	2
5	690117013	Facet plate Ø16	4	4	4	4	4
6	690113008	Self-locking nut M16	2	2	2	2	2
7	690117005	Facet plate Ø20	8	8	8	8	8
8	690113009	Self-locking nut M20	8	8	8	8	8
9	690103173	Bolt M20x70 10.9 Before machine no. 347965	4	4	4	4	4
10	0229250	Bolt Hexagon M20x70 8.8 UH fzb From machine no. 347965	4	4	4	4	4

Centersection

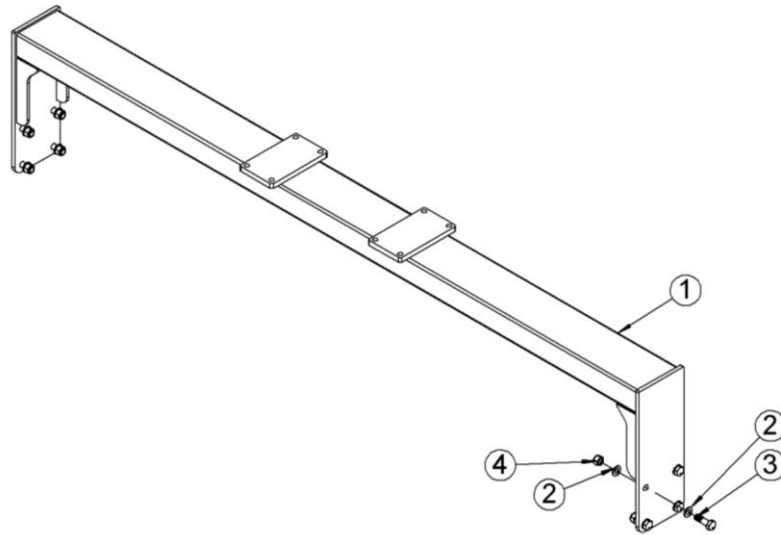

Pos	Item no.	Designation	12,3m	15,3m	16,3m	18,3m	20,3m
1	630670280	Centre section	1	1	1	1	1
2	690117005	Facet plate Ø20	16	16	16	16	16
3	690103147	Bolt M20x65 8.8	8	8	8	8	8
4	690113009	Selflocking nut M20	8	8	8	8	8

Hydraulics

Bracket for accumulator

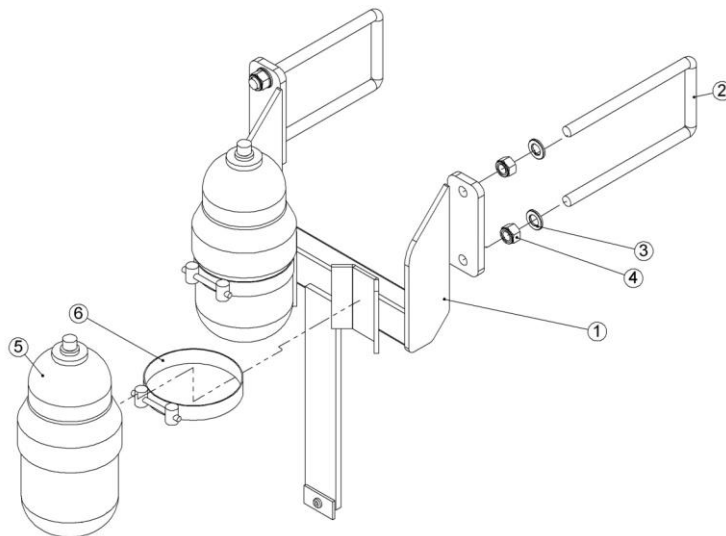

Pos.	Item no.	Designation	12.3m	15.3m	16.3m	18.3m
1	630670195	Bracket for accumulator	1	1	1	1
2	690110106	U-bolt M16x200x100x200	2	2	2	2
3	690117013	Facet plate Ø16	4	4	4	4
4	690113008	Self-locking nut M16	4	4	4	4
5	690206510	Accumulator HST 2,3L – 40bar	2	2	2	2
6	690106511	Clamp Ø122 – 130	2	2	2	2

Hydraulic circle: Centre section / chain cylinder for outer wing section

Check number and measurements of all hoses before ordering the spare parts.

Note:
Check number and measurements of all hoses before ordering the spare parts

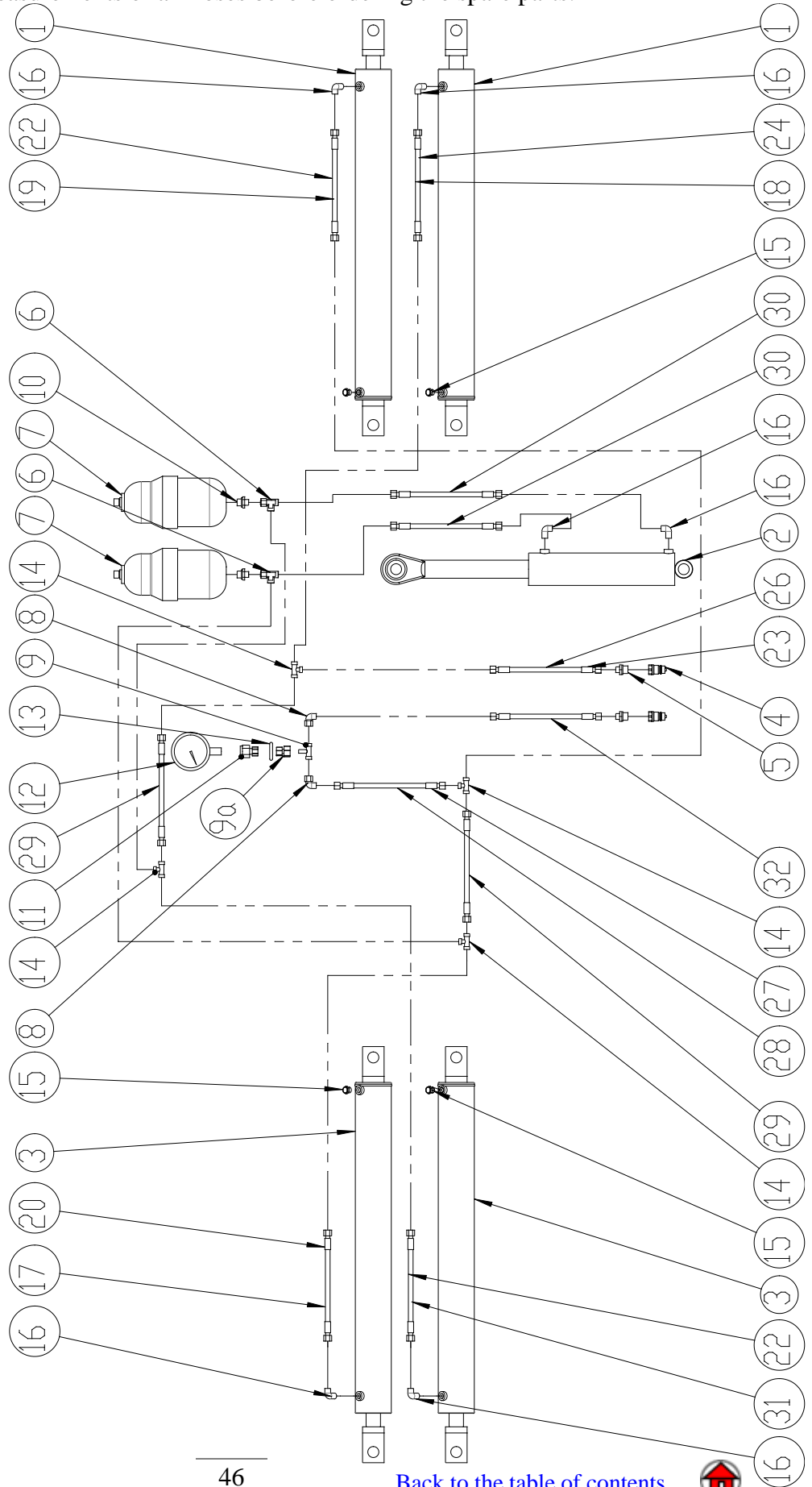

2024

Pos.	Item no.	Designation	12.3	15.3	16,3	18,3	20,3
1	690200115	Cylinder 90/40x800	2	2			
1	690200325	Cylinder 100/40x1100, right			2	2	
1	69020326	Cylinder 110/50x1100, right					2
2	690200180	Cylinder 80/40x280	1	1	1	1	1
3	690200190	Cylinder 90/40x800	2	2			
3	690200335	Cylinder 100/40x1100, left			2	2	
3	690200336	Cylinden 110/50x1100, left					2
4	690203001	Quick coupling 1/2" E402, male	2	2	2	2	2
5	690203003	Fitting straight Ø10 x1/2" BSP	2	2	2	2	2
6	690203120	Fitting T 10 L, premounted w/O-ring	2	2	2	2	2
7	690206510	Accumulator HST 2,3 L -40 bar	2	2	2	2	2
8	690203016	Fitting 10mm, premounted w/O-ring	2	2	2	2	2
9	690203015	Collector T10	1	1	1	1	1
9a	690203024	Reverse collector Ø10light/Ø10heavy	1	1	1	1	1
10	690203096	Fitting straight M18x1,5x10mm	2	2	2	2	2
11	690206823	Pressure gauge fitting Ø10 x 1/2"	1	1	1	1	1
12	690206822	Pressure gauge 250 bar, ø100	1	1	1	1	1
13	690110003	U-bolt M8x60xø35	1	1	1	1	1
14	690203015	Fitting T10	4	4	4	4	5
15	690206001	Filter plug 3/8"	4	4	4	4	4
16	690203006	Fitting, 90angle 10-3/8" BSP	6	6	6	6	6
17	690201005	Hydraulic hose 3300 mm 1/4" st/st	1				
18	690201007	Hydraulic hose 3700 mm 1/4" st/st		1	1	1	
19	690201060	Hydraulic hose 3000 mm 1/4" st/st	1				
20	690201029	Hydraulic hose 4300 mm 1/4" st/st		1	1	1	2
22	690201038	Hydraulic hose 4000 mm 1/4" st/st		2	2	2	1
22	690201047	Hydraulic hose 4610 mm 1/4" st/st					1
23	690201074	Hydraulic hose 7450 mm 1/4" st/st	1				
24	690201033	Hydraulic hose 2500 mm 1/4" st/st	1				
26	690201073	Hydraulic hose 8600 mm 1/4" st/st	1	1			
26	690201075	Hydraulic hose 9100 mm 1/4" st/st			1	1	
26	690201078	Hydraulic hose 9500 mm 1/4" st/st					2
27	690201011	Hydraulic hose 5350 mm 1/4" st/st		1			
27	690201025	Hydraulic hose 5640 mm 1/4" st/st		1			
27	690201038	Hydraulic hose 4000 mm 1/4" st/st	1				
27	690201047	Hydraulic hose 4610 mm 1/4" st/st					1
27	690201079	Hydraulic hose 6500 mm 1/4" st/st					1
27	690201012	Hydraulic hose 6000 mm 1/4" st/st			1	1	
29	690201009	Hydraulic hose 350 mm 1/4" st/st	2	2	2	2	2
30	690201064	Hydraulic hose 820 mm 1/4" st/st	2	2	2	2	2
31	690201070	Hydraulic hose 2800 mm 1/4" st/st	1				



32	690201048	Hydraulic hose 3610 mm 1/4" st/st	1	1	1	1	1
----	-----------	-----------------------------------	---	---	---	---	---



Hydraulic circle: Side section / wheel frame / locking claw

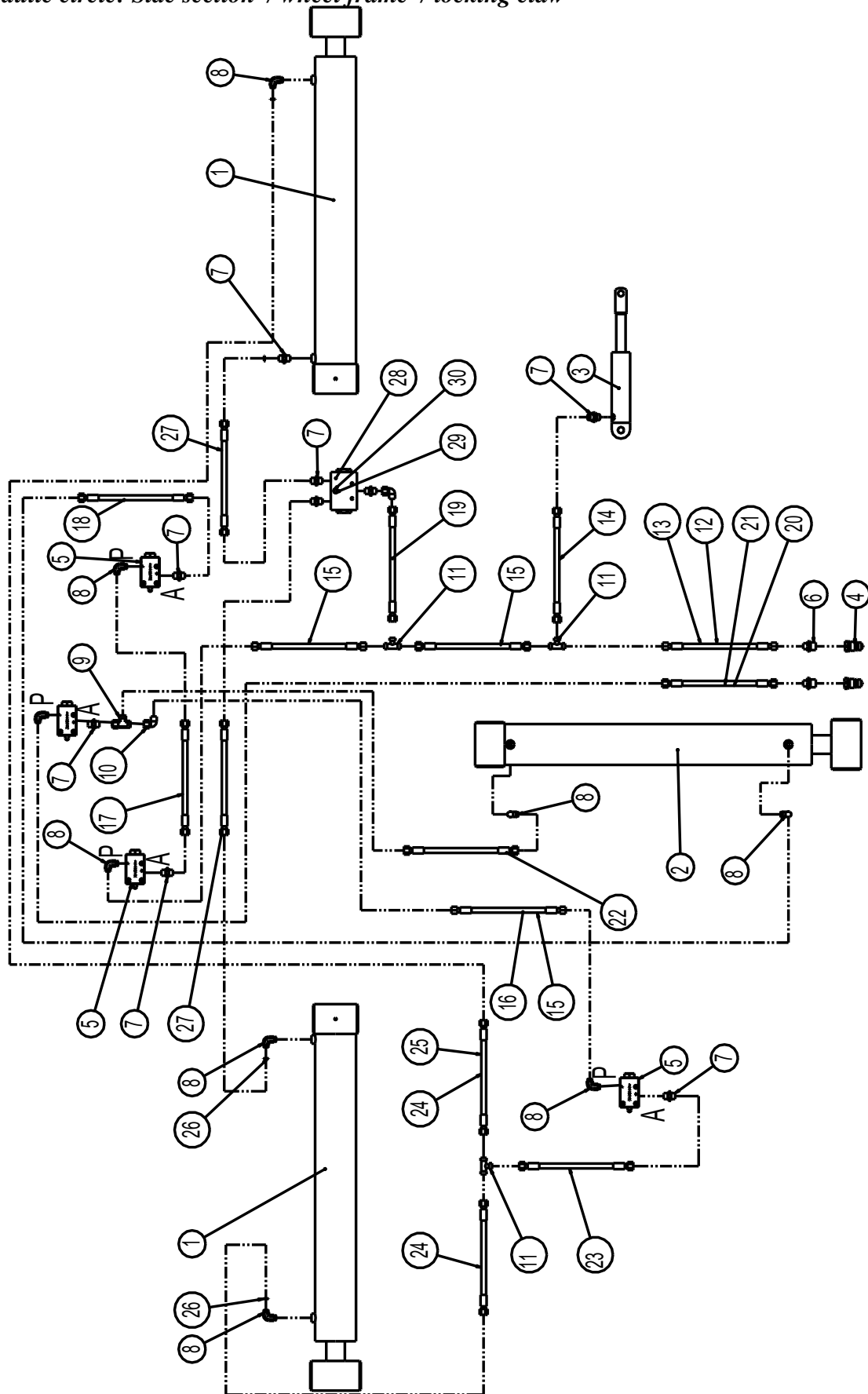

Pos.	Item no.	Designation	12,3	15,3	16,3	18,3	20,3
1	690200029	Cylinder 100/50x700 ϕ 35/ ϕ 35	2	2			
1	690200315	Cylinder 110/60x1000 ϕ 35/ ϕ 35			2	2	2
2	690200020	Cylinder 100/50x700 ϕ 35/ ϕ 35	1	1			
2	690200310	Cylinder 110/50x700 ϕ 35/ ϕ 35			1	1	1
2	690200360	Cylinder 125/70x700 ϕ 40/ ϕ 40 From machin no 347462			1	1	1
3	690200170	Cylinder 40/25x80	1	1	1	1	1
4	690203001	Quick coupling 1/2" E402, male	2	2	2	2	2
5	690207101	Stop valve	4	4	4	4	4
5a	0234810	Bolt M8x50mm 8.8 for stop valve	8	8	8	8	8
6	690203003	Fitting straight ϕ 10 x1/2" BSP	2	2	2	2	2
7	690203002	Fitting straight 10-3/8" BSP	6	6	6	6	6
8	690203006	Fitting 90angle 10-3/8" BSP	9	9	9	9	9
9	690203120	Fitting T 10 L, premounted w/O-ring	2	2	2	2	2
9	690203120	Fitting T 10 L, premounted w/O-ring After mounting of flowdivider			1	1	1
10	690203016	Fitting 90angle 10mm, premounted w/O-ring	1	1	1	1	1
11	690203015	Fitting T10	3	1	1	1	1
12	690201004	Hydraulic hose 4950 mm 1/4" st/st	1				
13	690201025	Hydraulic hose 5640 mm 1/4" st/st		1			
13	690201012	Hydraulic hose 6000 mm 1/4" st/st			1	1	
13	690201079	Hydraulic hose 6500 mm 1/4" st/st					1
14	690201015	Hydraulic hose 710 mm 1/4" st/st	2	2	1	1	1
14	690201052	Hydraulic hose 935 mm 1/4" st/st			1	1	1
15	690201020	Hydraulic hose 1625 mm 1/4" st/st	2	3	3	3	3
16	690201055	Hydraulic hose 1010 mm 1/4" st/st	1				
17	690201041	Hydraulic hose 1850 mm 1/4" st/st	1	1	1	1	1
18	690201070	Hydraulic hose 2800 mm 1/4" st/st	1	1	1	1	1
18	690201060	Hydraulic hose 3000 mm 1/4" st/st			1	1	1
19	690201059	Hydraulic hose 350 mm 1/4" st/st	1	1	1	1	1
19	690201053	Hydraulic hose 1260 mm 1/4" st/st After mounting of flowdivider			1	1	1
20	690201073	Hydraulic hose 8600 mm 1/4" st/st		1			
20	690201075	Hydraulic hose 9100 mm 1/4" st/st			1	1	
20	690201078	Hydraulic hose 9500 mm 1/4" st/st					1
21	690201066	Hydraulic hose 7800 mm 1/4" st/st	1				
22	690201013	Hydraulic hose 1770 mm 1/4" st/st	1	1			
22	690201041	Hydraulic hose 1850 mm 1/4" st/st			1	1	1
23	690201060	Hydraulic hose 3000 mm 1/4" st/st	1	1			
23	690201022	Hydraulic hose 3140 mm 1/4" st/st			1	1	1
24	690201036	Hydraulic hose 1590 mm 1/4" st/st	1	1			
24	690201068	Hydraulic hose 1950 mm 1/4" st/st			1	1	1
26	690207902	Restrictor nozzle ϕ 1,4 mm (Bef. Serno. 351044)	4	4	4	4	4
26	690207902	Restrictor nozzle ϕ 1,4 mm (After mounting of flowdivider from serialno. 351044 at 16,3-18,3-20,3m)	4	4	0	0	0
27	690201042	Hydraulic hose 500 mm 1/4" st/st			2	2	2
28	0442775	Flowdivider 3/8" 50x50x% 10-20 l/min			1	1	1
29	0234390	Bolt M6x50			3	3	3
30	0272240	Facet plate 6mm fzb			3	3	3

Note: Check number and measurements of all hoses before ordering the spare parts.



Hydraulic circle: Supporting leg

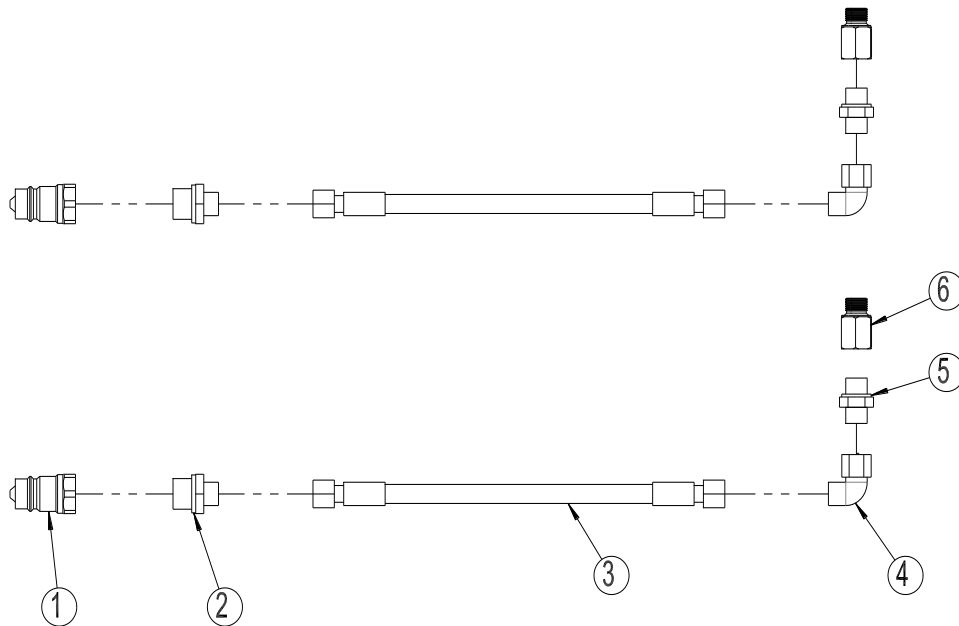

Pos.	Item no.	Designation	12.3	15.3	16,3	18,3	20,3
1	690203001	Quick coupling ½", male	2	2	2	2	2
2	690203003	Fitting, straight Ø10 x1/2" BSP	2	2	2	2	2
3	690201048	Hydraulic hose 3610 mm ¼" st/st	2	2	2	2	2
4	690203016	Fitting 90angle 10mm	2	2	2	2	2
5	690203002	Fitting, straight 10-3/8" BSP	2	2	2	2	2
6	690203903	Fitting 3/8"-3/8" L=22	2	2	2	2	2



2024

Brakes

Hydraulic brake

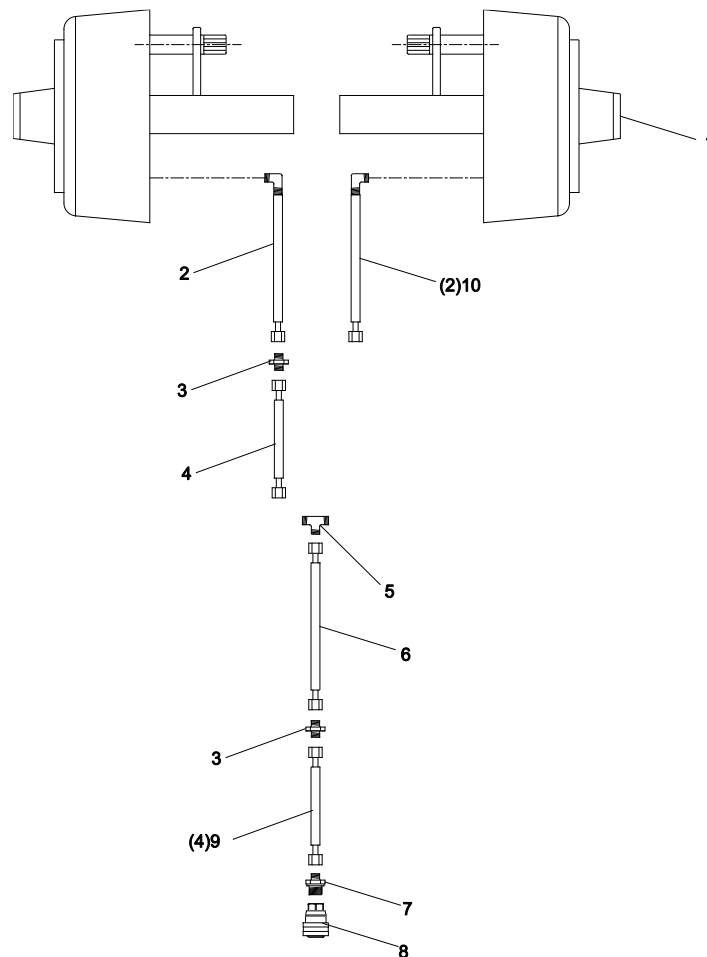

Pos.	Item no.	Designation	12,3	15,3	16,3	18,3	20,3
1	690141032	Hub with brake (inner cylinder) Ended	2	2			
1	7297579	Hub with brake TVZ From May 2021	2	2			
1	690141050	Hub with brake 5000kg			2	2	
1	690141060	Hub with brake 6000kg From oct 2013			2	2	2
2(2)	690201071	Hydraulic hose 500mm 1/4" st/90	2	2			
3	690203018	Fitting 10mm	1	1	1	1	1
4(4)	690201015	Hydraulic hose 710mm 1/4" st/st	1	1	1		
5	690203015	Fitting T10	1	1	1	1	1
6	690201075	Hydraulic hose 9100 mm 1/4" st/st	1				
6	690201065	Hydraulic hose 10000mm 1/4" st/st		1	1	1	1
7	690203003	Fitting, straight 10-1/2" BSP	1	1	1	1	1
8	690203013	Quick coupling, 1/2" BSP ISO567	1	1	1	1	1
9	690201052	Hydraulic hose 935 mm 1/4" st/st			1	1	1
10	690201064	Hydraulic hose 820 mm 1/4" st/st			1	1	1
10	690201009	Hydraulic hose 350 mm 1/4" st/st			1	1	1

Note: Check number and measurements of all hoses before ordering the spare parts.



Air brake

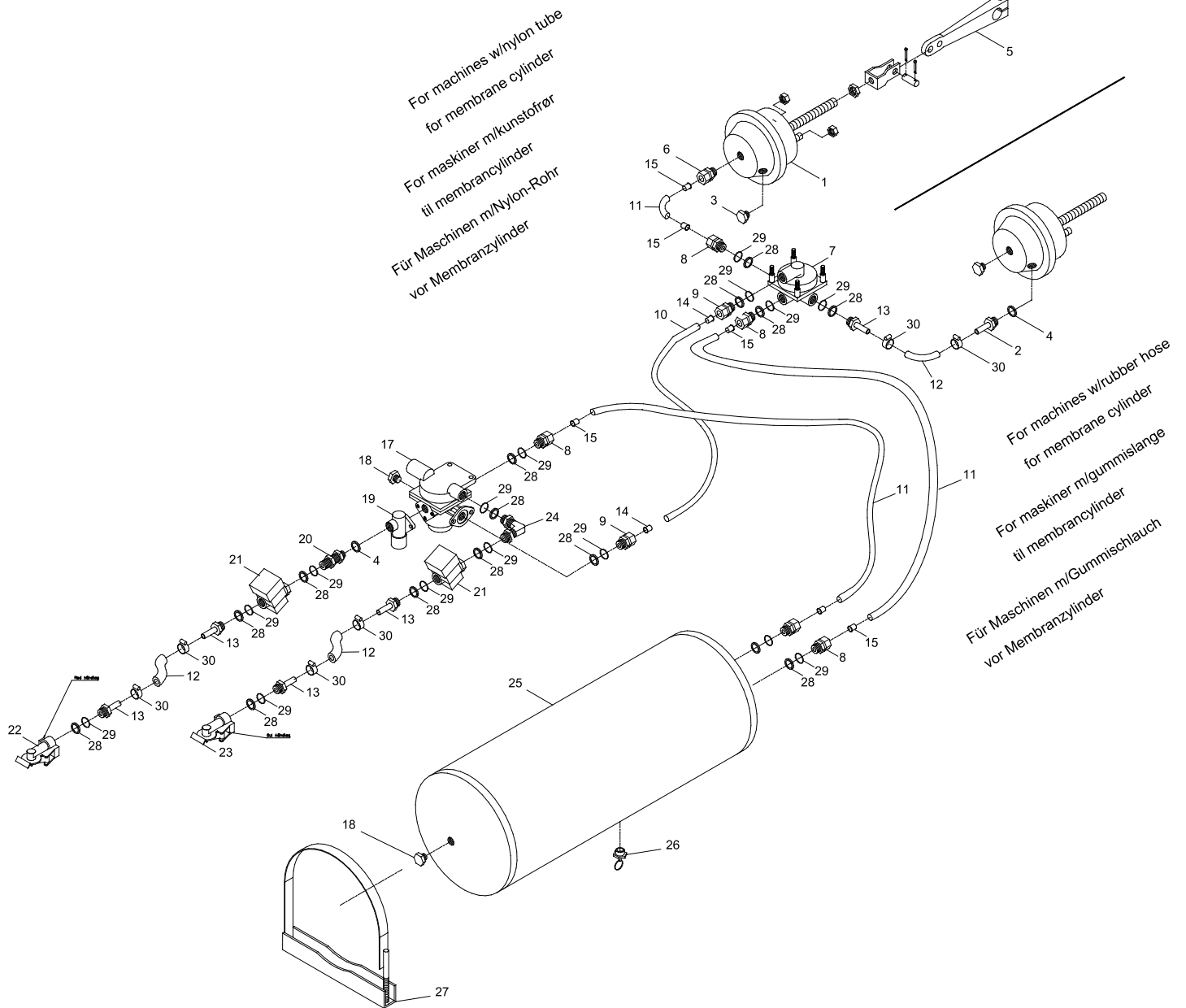

Pos.	Item no.	Designation	w/nylon tube f/ membrane cyl.	w/rubber hose for membrane cyl.
1	690190001	Membrane cylinder 16"	2	2
2	690190070	Hose fitting M16x1,5 m/ Ø12 fitting	0	2
3	690190005	Test fitting, straight M16x1,5	2	2
4	690208102	Bonded seal PP 45-12	1	3
5	690190010	Mounting set, short U-bracket	2	2
6	690202930	Fitting, straight, lige M16x1,5, Ø15 hose	2	0
7	690190015	Relay valve M22x1,5	1	1
8	690202941	Fitting, straight M22x1,5, Ø15 hose	6	4
9	690202940	Fitting, straight M22x1,5, Ø10 hose	2	2
10	690190080	Nylon tube Ø10x1mm	1	1
11	690190085	Nylon tube Ø15x1,5mm	4	2
12	690190105	Hose Ø14,5x5mm	2	4
13	690190073	Hose fitting M22x1,5, m/Ø12 fitting	4	6
14	690190090	Support bushing for tube Ø10x1,5mm	2	2
15	690190095	Support bushing for tube Ø15x1,5mm	8	4
17	690190025	Trailer air brake valve M22x1,5	1	1
18	690190026	Plug	2	2
19	690190035	Relief valve	1	1
20	690203420	Fitting, straight M16x1,5+M22x1,5	1	1
21	690190040	Filter M22x1,5	2	2
22	690190045	Hose coupling M22x1,5 (red)	1	1
23	690190046	Hose coupling M22x1,5 (yellow)	1	1
24	690190030	V-Fitting M22x1,5	1	1
25	690190050	Air receiver 40ltr	1	1
26	690190051	Drainage valve	1	1
27	690190052	Suspension for air receiver	2	2
28	690190060	Pressure ring M22x1,5	15	15
29	690190065	O-ring M22x1,5	15	15
30	690109305	Clamp 15-24 mm	4	8



LED - Light set

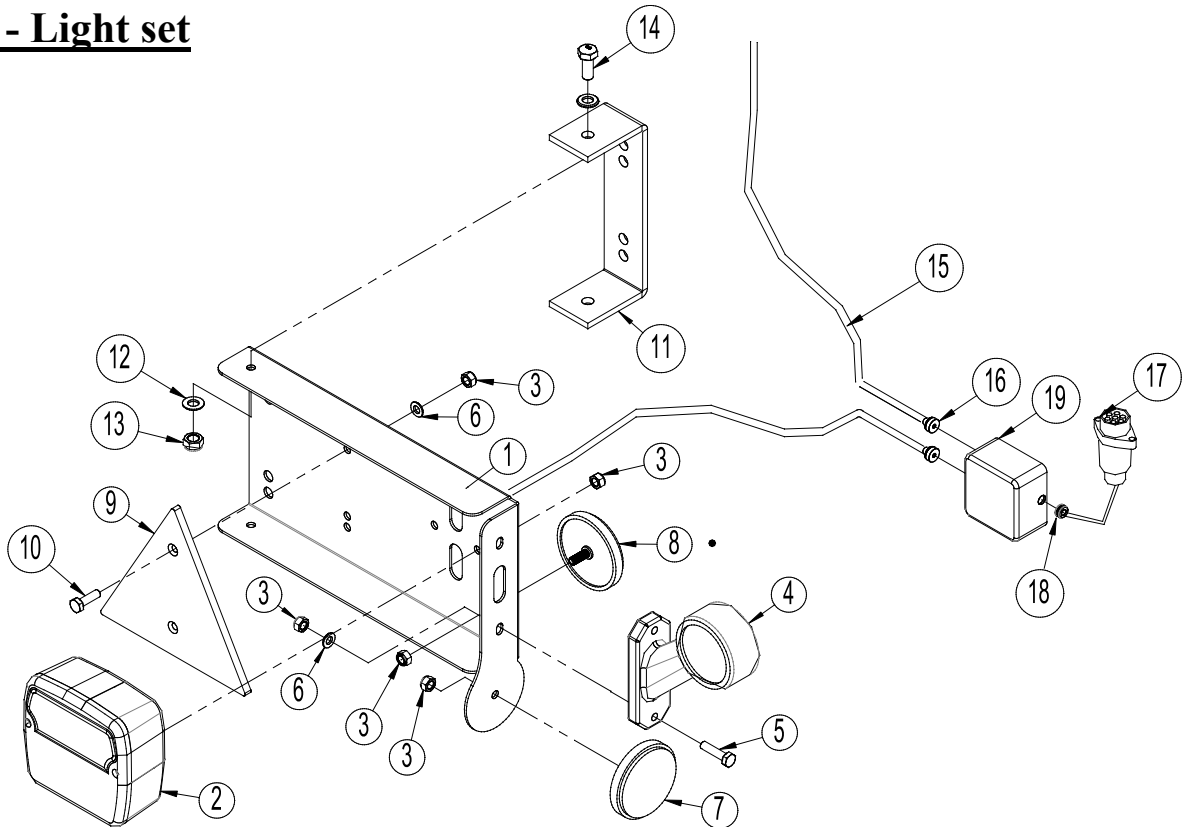

Pos.	Item no.	Designation	Qty.
1	7357505	Lightbox (L)	1
	7357508	Lightbox (R)	1
2	7357504	Rear light	2
3	0264030	Locking nut M5	16
4	7357507	Marking lights (L)	1
	7357509	Marking lights (R)	1
5	0234340	Bolt M5x25	4
6	0272240	Facet plate Ø5	8
7	0656240	Reflex, yellow	2
8	0656250	Reflex, white	2
9	690160017	Reflex, red	2
10	0234330	Bolt M6x20	4
11	7357516	Bracket	2
12	0272250	Facetskive Ø8	16
13	0264050	Locking nut M8	8
14	0234750	Bolt M8x20	4
15	690160080	Cable 5 x 1mm ² (Inform about length by ordering sparepart)	
16	7357545	Rutaseal nipple M20 8-12mm Grey RAL7001	2
17	690160070	Plug 7 poles DIN 72 577 – ISO 1724	1
18	7357546	Rubberbushing Nr. 38A Ø10/3 black	1
19	0520492	Junction box 105x105x60	1

Note:

Check number and measurements of all cables before ordering the spare parts.



Lighting set: El. diagram

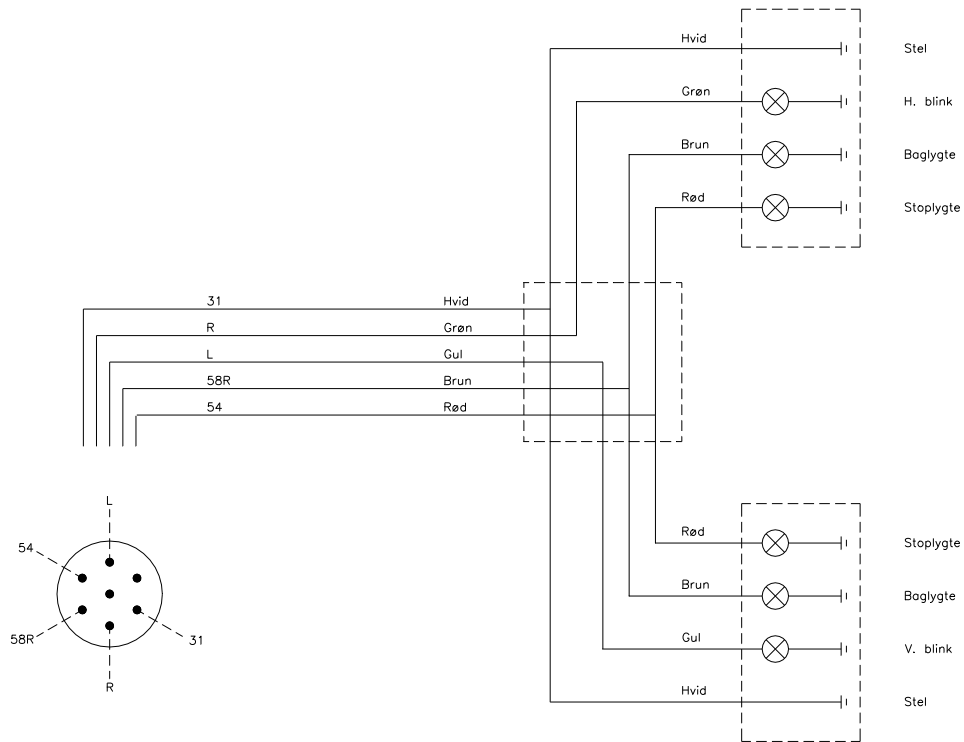

Notes:



as it looks
As good as it looks
As good as it looks
As good as it looks
As good as it looks

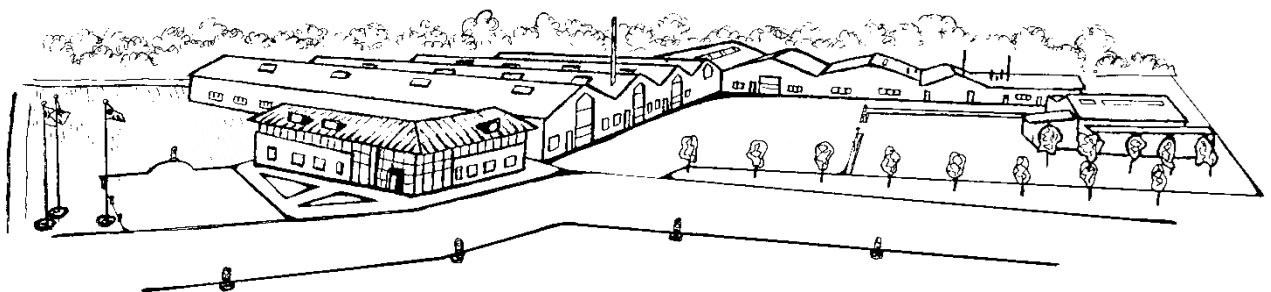

The design is subject to modification without notice.